

Table of Contents

SECTION 1 ❖ SANITARY SEWER SYSTEM

	<u>Page No.</u>
PART 1 GENERAL.....	1
1.01 Section Includes.....	1
1.02 Design Criteria and Permitting.....	1
1.03 References.....	1
1.04 Submittals.....	3
1.05 Delivery, Storage, and Handling.....	4
1.06 Quality Assurance.....	4
1.07 Warranty/Service Agreement.....	4
PART 2 ALLOWABLE PRODUCTS AND MATERIALS.....	5
2.01 Pipe and Accessories.....	5
2.02 Manholes.....	8
2.03 Castings.....	9
2.04 Transition Couplings for Gravity Sewer Pipe.....	10
2.05 Valves.....	10
2.06 Wastewater Pump Station.....	12
2.07 Engine Generator System with Automatic Transfer Switch.....	20
PART 3 EXECUTION / INSTALLATION.....	25
3.01 Pipe and Accessories.....	25
3.02 Manholes.....	36
3.03 Valves and Fittings.....	37
3.04 Pump Station.....	37
3.05 Engine Generator System with Automatic Transfer Switch.....	38
PART 4 TESTING AND START-UP.....	38
4.01 Pipe and Accessories.....	38
4.02 Manholes.....	42
4.03 Pump Station.....	42
4.04 Engine Generator System with Automatic Transfer Switch.....	43
4.05 Closed Circuit TVing of Gravity Lines.....	44
4.06 "As-Constructed" Drawings.....	44



SECTION 1

SANITARY SEWER SYSTEM

PART 1 GENERAL

1.01 SECTION INCLUDES

- A. Work under this section includes, but is not limited to piping, valves, pumps, generators and appurtenances for a complete sanitary sewer collection system associated with pressure sewer.

1.02 DESIGN CRITERIA AND PERMITTING

- A. The design of all public sanitary sewer systems that are to become a part of the Town of Granite Falls' wastewater collection system, shall be in accordance with the N.C. Department of Environment and Natural Resources' publications "Minimum Design Criteria for the Permitting of Gravity Sewers" and "Minimum Design Criteria for the Permitting of Pump Stations and Force Mains" and the requirements contained herein.
- B. The Engineer and Contractor shall prepare and submit all applicable permit applications required by federal, state and local authority. All fees are the responsibility of the Contractor.
- C. Sanitary sewers shall be installed in street rights-of-way or permanent easements. Minimum easement widths shall be as follows:
 - 1. Depth of Sewer $\leq 8'$; 20 feet
 - 2. $8' < \text{Depth of Sewer} \leq 12'$; 30 feet
 - 3. $12' < \text{Depth of Sewer} \leq 14'$; 40 feet
 - 4. Depth of Sewer $> 14'$; To Be Determined by Town

1.03 REFERENCES

- A. Publications are referred to in the text by basic designation only.
 - 1. American Society for Testing and Materials (ASTM)
 - a. A48 Gray Iron Castings
 - b. A126 Gray Iron Castings and Valves, Flanges and Pipe Fittings
 - c. A536 Ductile Iron Castings
 - d. C478 Precast Reinforced Concrete Manhole Sections
 - e. C890 Minimum Structural Design Loading for Monolithic or Sectional Precast Concrete Water and Wastewater Structures
 - f. C923 Resilient Connectors Between Reinforced Concrete Manhole Structures, Pipes and Laterals
 - g. C990 Joints for Concrete Pipe, Manholes, and Precast Box Sections Using Performed Flexible Joint Sealants
 - h. C1244 Test Method for Concrete Sewer Manholes by the Negative Air Pressure

- i. D698 Test Methods for Laboratory Compaction Characteristics of Soil Using Standard Effort (12 400 ft-lbf/ft³ (600 kN-m/m³))
 - j. D1248 Polyethylene Plastics Molding and Extrusion Materials
 - k. D1586 Standard Test Method for Standard Penetration Test (SPT) and Split-Barrel Sampling of Soils
 - l. D1784 Rigid Poly(Vinyl Chloride) (PVC) Compounds and Chlorinated Poly(Vinyl Chloride) (CPVC) Compounds
 - m. D1785 Poly(Vinyl Chloride) (PVC) Plastic Pipe, Schedules 40, 80 &120
 - n. D2241 Poly(Vinyl Chloride) (PVC) Pressure Rated Pipe (SDR Series)
 - o. D2321 Recommended Practice for Underground Installation of Flexible Thermoplastic Sewer Pipe
 - p. D3034 Type PSM Poly(Vinyl Chloride) (PVC) Sewer Pipe and Fittings
 - q. D3139 Joints for Plastic Pressure Pipes Using Flexible Elastomeric Seals
 - r. F477 Elastomeric Seals (Gaskets) for Joining Plastic Pipe
 - s. F794 Poly(Vinyl Chloride) (PVC) Profile Gravity Sewer Pipe and Fittings Based on Controlled Inside Diameter
2. American Water Works Association (AWWA)
- a. C104 Cement-Mortar Lining for Ductile-Iron Pipe and Fittings for Water
 - b. C110 Ductile-Iron and Gray-Iron Fittings, 3 inch through 48 inch, for Water and Other Liquids
 - c. C115 Flanged Ductile-Iron Pipe with Threaded Flanges
 - d. C151 Ductile-Iron Pipe, Centrifugally Cast in Metal Molds or Sand-Lined Molds, for Water or Other Liquids
 - e. C153 Ductile-Iron Compact Fittings, 3 inch through 16 inch, for Water and Other Liquids
 - f. C504 Rubber Seated Butterfly Valves
 - g. C507 Ball Valves, 6 inch through 48 inch
 - h. C508 Swing-Check Valves for Waterworks Service, 2 inch Through 24 inch NPS
 - i. C509 Resilient-Seated Gate Valves for Water Supply Service
 - j. C512 Air-Release, Air / Vacuum, and Combination Air Valves for Waterworks Service
 - k. C515 Reduced Wall, Resilient-Seated Gate Valves for Water Supply Services
 - l. C550 Protective Epoxy Interior Coatings for Valves and Hydrants
 - m. C600 Standard for Installation of Ductile Iron Water Mains and Their Appurtenances
 - n. C605 Underground Installation of Polyvinyl Chloride (PVC) Pressure Pipe and Fittings for Water
 - o. C900 Polyvinyl Chloride (PVC) Pressure Pipe and Fabricated Fittings, 4 inch through 12 inch, for Water Distribution

- p. M23 PVC Pipe - Design Installation
- 3. National Sanitation Foundation (NSF) Standards
 - a. 14 Plastic Piping Components and Related Materials
- 4. UNI-BELL Plastic Pipe Association (UNI)
 - a. B-5 Recommended Practice for the Installation of Polyvinyl Chloride (PVC) Sewer Pipe
 - b. B-6 Recommended Practice for Low-Pressure Air Testing of Installed Sewer Pipe

1.04 SUBMITTALS

- A. Submit the following to the Town's Public Works Department prior to beginning work:
 - 1. All related Design Calculations, sealed as required by a Professional Engineer licensed to practice in North Carolina.
 - 2. Affidavit of Compliance: Affidavit shall attest that supplied products conform to the referenced standard and this specification and that tests set forth in each applicable referenced publication have been performed and that test requirements have been met. Affidavits shall be provided for all pipe, ductile iron pipe liner, valves, pre-cast structures, pumps, generators, switch gears and other items as requested by the Town.
 - 3. Catalog Data: Submit manufacturer's standard drawings or catalog cuts for all pipe, ductile iron pipe liner, valves, pre-cast structures, (including steps, pipe connectors, joint materials, castings) service saddles, pumps, access hatches, lifting hoists, float switches, pressure gauges, generators, switch gears, and other items as requested by the Town.
 - 4. Shop Drawings: For pump stations submit shop drawings for the following:
 - a. Pumps
 - b. Pre-Cast Wet Wells
 - c. Valve Vault
 - d. Access Hatches
 - e. Trash Basket
 - f. Lifting Hoist
 - g. Float Switches
 - h. Pressure Gauges
 - i. Valves
 - j. Dimensional drawing showing position of equipment in respect to access hatches.
 - k. Electrical diagram(s) for complete operating system, including pumps, generator, automatic switch gear and control panel.
 - l. Layout of control panel face.
 - 5. Manufacturer's Installation Procedures.

6. Prior to final acceptance, submit test reports, in booklet format, including but not necessarily limited to the following:
 - a. Field Test report for each section of pipe installed including:
 - 1) Pressure tests for force mains.
 - 2) Low pressure air test for gravity mains.
 - 3) Vacuum test for manholes or other pre-cast structure
 - b. Pump drawdown tests.
 - c. Air/vacuum relief valves, surge relief valves, check valves, etc.
 - d. Start-up report and load test results, including operation of automatic switch gear.
7. Prior to final acceptance, submit manufacturer's complete operation and maintenance manuals for all valves and all components of the pump station including the generator and automatic transfer switch.
8. Prior to final acceptance, provide a parts list for each piece of equipment including type and quantity of part recommended for stock.

1.05 DELIVERY, STORAGE, AND HANDLING

- A. All materials and equipment shall be handled and stored in accordance with the manufacturer's recommendations.

1.06 QUALITY ASSURANCE

- A. All parts and materials incorporated into a project shall be new and unused.
- B. Contractors must be licensed by the N.C. Licensing Board for General Contractors and have a classification and a cost limitation appropriate for the work to be performed.

1.07 WARRANTY/SERVICE AGREEMENT

- A. Line Work
 1. All materials and workmanship shall have a one-year warranty from the date of final acceptance by the Town. A warranty inspection will be made jointly by the Town and the Contractor approximately eleven (11) months after acceptance to identify needed repairs. All labor, equipment and materials needed to make these repairs shall be the responsibility of the Contractor.
- B. Pump Station
 1. Pumps shall be provided with the manufacturer's standard warranty or a minimum of one (1) year, whichever is greater. Warranty shall cover all costs including, but not limited to, parts, labor, equipment and travel. Warranty will begin on the date of Substantial Completion.
 2. Engine generator system and transfer switch shall be provided with a five (5) year warranty. Warranty shall cover all costs including, but not limited to, parts, labor, equipment and travel. Warranty will begin on the date of Substantial Completion.

3. A two-year service plan for the engine generator set to become effective on the date of Substantial Completion shall be provided. The plan shall include semi-annual inspections. Provide a detailed report of each service visit. Each of the following checks and services shall be performed at least annually:
 - a. Oil change; check for leaks.
 - b. Oil filter replacement.
 - c. Engine check; inspect, run and test.
 - d. Fuel tank test for water and leaks.
 - e. Check for hose leaks.
 - f. Top off of fluids.
 - g. Automatic transfer switch test.
 - h. Inspection of housing for corrosion, unusual noises, and excessive vibration.
 - i. Inspection and cleaning of batteries. Seal terminals and check voltage.
 - j. Analysis of oil for contaminants.
 - k. Fuel filter replacement.
 - l. Replace air filter.
4. All other components of the pump station, including the control panel shall be provided with a minimum of a one (1) year warranty. Warranty shall cover all costs including, but not limited to, parts, labor, equipment and travel. Warranty will begin on the date of Substantial Completion. A warranty inspection will be made jointly by the Town and Contractor prior to the expiration of the various warranties.

PART 2 ALLOWABLE PRODUCTS AND MATERIALS

2.01 PIPE AND ACCESSORIES

- A. Ductile Iron Pipe for Gravity Sewer and Force Main
 1. General
 - a. Ductile Iron Pipe (DIP) shall meet the requirements of AWWA C-151 and as required herein.
 - b. Ductile Iron Sewer Pipe must be easily recognized by brownish red bells and spigots, as well as, exterior stenciling of the words "For Sewer Only".
 2. Thickness Class
 - a. Pipe thickness class shall be determined by pipe diameter, system working pressure and anticipated laying conditions. In general, for a 12-inch or less diameter pipe with a burial depth of 15 feet or less in a Type 2 laying condition, the pipe pressure class will be Class 350.
 3. Pipe Lining
 - a. When used in sanitary sewer applications, ductile iron pipe and fittings shall be lined with 40 mils of Protecto 401 Ceramic Epoxy liner or equal. All bells and spigots shall be lined with a minimum of 8 mils of Protecto 401 or approved equal.

- b. The liner shall meet the manufacturer's recommendations.
4. Joints
- a. Ductile iron pipe for below ground service shall have push-on or mechanical joints, unless otherwise required by the Town and shall conform to AWWA C151.
 - b. Ductile iron pipe for above ground service shall have flanged joints unless otherwise required by the Town and shall conform to AWWA C115.
 - c. Ductile iron pipe on piers shall have rigid restrained joints as recommended by the pipe manufacturer.
5. Restrained Joints
- a. Provide restrained joint pipe at fittings and valves as calculated by the Design Engineer and approved by the Town.. Restrained joints shall be Snap-Lok (Griffin Pipe), Flex Ring and Lok-Ring (American), TR Flex (U.S. Pipe) or approved equal.
 - b. Restrained joint pipe and fittings shall meet all AWWA standards and other requirements as specified above for standard ductile iron pipe and fittings unless addressed herein.
 - c. Field made joints are allowable but should be avoided where possible. Careful planning to locate field cuts in standard pipe sections is preferred. For field made joints in restrained piping, use field weldments or an insert equal to TR Flex Gripper Rings or approved equal. Gasket type field made joints will not be allowed.
 - d. Restrained joint fittings shall be provided by the restrained joint pipe supplier where located within restrained joint pipe sections. Fittings shall be of the same model and type as the pipe supplied from the pipe manufacturer.
 - e. Restrained joint fittings may be push-on joint type.
 - f. Megalugs, Series 1100, as manufactured by EBAA Iron Sales or approved equal shall be allowable for restraint where approved by the Town.
 - g. The Contractor shall develop a field layout schedule and drawing for restrained joint pipe installations.
6. Fittings
- a. Fittings shall be made of ductile iron and shall conform to AWWA C110 or C150.
 - b. Fittings to be lined with 40 mils of Protecto 401 Ceramic Epoxy or equal.
- B. Polyvinyl Chloride (PVC) Pipe for Sewer Force Main
- 1. General
 - a. All PVC pipe shall be manufactured in accordance with AWWA C900.
 - 2. Pressure Class
 - a. Pressure class for the pipe will be dependant on system working pressure but will be a minimum of Class 150 with a standard dimension ratio of DR 18.
 - 3. Joints
 - a. Pipe shall have plain end and elastomeric-gasket bell ends.

4. Fittings
 - a. Fittings shall be made of ductile iron and shall conform to AWWA C110 or C150.
 - b. Fittings to be lined with 40 mils of Protecto 401 Ceramic Epoxy or equal.
- C. Polyvinyl Chloride (PVC) Pipe for Gravity Sewer
 1. General
 - a. All PVC sewer pipe 4-inches through 15-inches in diameter shall have a minimum Standard Dimension Ratio (SDR) of 21 and shall meet all requirements of ASTM Specification D3034.
 - b. For depths greater than 20 feet, all PVC sewer pipe 4-inches through 15-inches in diameter shall have a minimum Standard Dimension Ratio (SDR) of 19.
 - c. Nominal pipe length shall be a minimum of 13 feet.
 2. Joints
 - a. Pipe shall have an integral elastomeric-gasket bell end.
 - b. Gaskets shall be in conformance with ASTM F477.
- D. Services
 1. General
 - a. Unless otherwise directed by the Town, pipe for gravity sewer service laterals, including the cleanout stack, shall be PVC Schedule 40 pipe meeting the requirements of ASTM D1785, or ductile iron pipe.
 - b. All service connections to new lines shall be made by installing "wyes".
 2. Joints
 - a. Joints for PVC service pipe shall be solvent cement welded.
- E. Encasement Pipe
 1. Materials
 - a. Encasement pipe installed under Town maintained and NCDOT maintained roadways shall be in accordance with NCDOT's "Policies and Procedures for Accommodating Utilities on Highway Rights-of-Way".
 - b. Encasement pipe installed under railroads shall be in accordance with "Part 5.3, Specifications for Pipelines Conveying Non-Flammable Substances" as developed by the American Railway Engineering Association (AREA).
 - c. Pipe materials used for the carrier pipe shall be adjusted as needed to meet the requirements of the roadway or railroad owners.
 - d. Pipe supports used in the encasement pipe designed and manufactured for the support of the carrier pipe shall be as follows:
 - 1) Band and Riser Material: 14 gauge steel for band and riser except if the riser is over 6-inches high, the steel shall be 10 gauge for riser. Riser shall be of the channel shape. Band with risers shall have a fusion bonded PVC coating of a minimum of 10-mil thickness. Band shall be bolted together with stainless steel bolts, nuts and washers.
 - 2) Band Liner: Provide PVC liner a minimum of 0.09 inches.

- 3) Runners: Glass Reinforced Polyester or UHMW Polymer plastic. Runner shall be a minimum of 1-inch wide and not more than 1-inch shorter than the bandwidth. Provide 2 top and 2 bottom runners for pipe sizes through 12-inches and 2 top and 4 bottom runners for pipes over 12-inches.
- e. End seals installed on the encasement pipe may be a wrap around or a pull-on type. Seal shall be made of 1/8-inch thick synthetic rubber and shall be secured with stainless steel banding straps with worm gear tightening device. Alternate means of sealing the encasement may be approved by the Town.

2.02 MANHOLES

A. General

1. Manholes shall be made of pre-cast concrete sections in conformance with ASTM C478, N.C. Department of Transportation and the following requirements:
 - a. Standard manhole diameter shall be 4 feet unless an inside drop structure is installed, the depth exceeds 15 feet or the number of pipes, and/or their diameter entering the manhole is such that a larger manhole is required. In these cases the minimum diameter shall be 5 feet or as determined by the Town.
 - b. Pre-cast concrete manholes shall be as manufactured by Adams Concrete, Carolina Precast Concrete, Inc., D&M Concrete Specialties, Inc., N.C. Products Corp., Stay Right Tank, Tindall Concrete Products, Inc. or approved substitute.

B. Pre-Cast Sections

1. Minimum wall thickness shall be 5-inches.
2. Base: Cast monolithically without construction joints or with an approved PVC waterstop in the cold joint between the base slab and the walls. The width of the base extensions on Extended Base Manholes shall be no less than the base slab thickness.
3. Riser: Minimum lay length of 16-inches.
4. Eccentric Cone: Top inside diameter shall be 24-inches. Width of the top ledge shall be no less than the wall thickness required for the cone section.
5. Transition Cone: Provide an eccentric transition from 60-inch and larger manholes to 48-inch diameter risers, cones, and flat slab top sections. Minimum slope angle for the cone wall shall be 45 degrees.
6. Flat Slab Top: Designed for HS-20 traffic loadings as defined in ASTM C890. Items to be cast into Special Flat Slab Tops shall be sized to fit within the manhole ID and the top and bottom surfaces. Provide a float finish for exterior slab surface.
7. Pre-Cast or Core Holes for Pipe Connections: Diameter of hole shall not exceed outside diameter of pipe by more than 3-inches.
8. Grade Rings: May be used to adjust frame and cover to finished grade.
9. Grade Rings shall be no less than 4-inches in height and no more than two (2) may be used. Maximum total height shall not exceed 12-inches.

10. Lifting Devices: Devices for handling pre-cast components shall be provided by the pre-cast manufacturer and comply with OSHA Standard 1926.704.

C. Joints

1. Manufacturer in accordance with tolerance requirements of ASTM C990 for butyl type joints.
2. Minimize number of joints. Do not use riser section for manholes up to 6 feet tall and no more than one riser for each additional 4 feet in height.
3. Flexible Joint Sealants: Preformed butyl rubber based sealant material conforming to Federal Specification SS-S-210A, Type B and ASTM C990.
4. External Seal: Polyethylene backed flat butyl rubber sheet no less than 1/16-inch thick and 6-inches wide.

D. Inverts

1. Brick and mortar or precast concrete invert.
2. Form and finish invert channel to provide a consistent slope from inlet(s) to outlet up to 4-inches.
3. Channel walls shall be formed to 3/4 of the height of the outlet pipe diameter.
4. Finish benches with a minimum uniform 1.5:12 slope. Provide a 1/4-inch radius at the edge of bench and trough.

E. Flexible Pipe Connectors

1. Provide flexible connectors for pipe to manhole that conform to ASTM C923.
2. Provide stainless steel pipe clamp type band around flexible connection to sewer pipe.

2.03 CASTINGS

A. General

1. Made of gray iron, ASTM A-48 - Class 30, or ductile iron, ASTM A536, grade 65-45-12.
2. Castings shall be free from imperfections not true to pattern. Casting tolerances shall be plus or minus 1/16-inch per foot of dimension. Top shall set neatly in frame, with edges machined for even bearing and proper fit to prevent rattling and flush with the edge of frame.
3. Castings shall be as manufactured by Neenah Foundry Co., U.S. Foundry & Manufacturing Corp., or Vulcan Foundry.

B. Manhole Frame and Cover:

1. Minimum clear opening shall be 22-inches.
2. Minimum weight for frame and cover shall be 310 pounds and suitable for Heavy Duty Highway Traffic Loads of H-20.
3. Frame shall have four 3/8-inch anchor bolt holes equally spaced.
4. Cast "Sanitary Sewer" on the cover. Casting shall bear the name of the manufacturer and the part number.
5. See details for various types of allowable covers. Utilize as appropriate for the intended application or as directed by the Town.

6. Bolt down covers shall be provided with four (4) 3/8-inch stainless steel hex head bolts at 90 degrees.

2.04 TRANSITION COUPLINGS FOR GRAVITY SEWER PIPE

- A. For new construction, pipe materials shall be comprised of only a single material between manholes. No changes in material are allowed between manholes.
- B. Pipe material changes between manholes may be permitted (in special circumstances as a repair option) provided there is not a substantial difference in inside diameters, a smooth uniform flow line is maintained and a watertight rubber sleeve or mechanical coupler conforming to ASTM C-425 is used to make the transition. Metal hardware shall be stainless steel. Transition sleeves shall be MaxAdapter manufactured by Gripper Gasket, LLC.

2.05 VALVES

A. General

1. Valves used in sewer applications shall meet the following requirements:
 - a. Open by **counterclockwise** rotation.
 - b. Shall be suitable for a working pressure of 150 pressure psi.
 - c. Equip valves with a suitable means of operation.
 - d. For buried valves over 5 feet deep, provide extension stems of cold rolled steel to bring the operating nut to within 2 feet of the ground surface.
 - e. Provide valve accessories as required for proper valve operation as recommended by valve manufacturer. Valve accessories shall be compatible to proper valve operation.
 - f. Similar valve types shall be of one manufacturer.
 - g. All valves shall be warranted for ten (10) years from date of installation against defective materials and workmanship.
 - h. Valves shall be manufactured by American Flow Control, Clow Valve Company, Kennedy Valve Company, M&H Valve Company, Mueller Company or U.S. Pipe and Foundry Company.

B. Gate Valves, Resilient-Seated

1. Gate valves 3-inch to 20-inch shall conform to AWWA C509 or AWWA C515 and to the following requirements:
 - a. O-ring stem seal on non-rising (NRS) stem valves.
 - b. Ends shall be mechanical joint for underground locations and flanged joint for above ground locations.
 - c. Valves shall be non-rising stem (NRS) with wrench nut for underground locations and Outside Screw and Yoke (OS&Y) with handwheel for above ground locations unless noted otherwise on the Drawings..

C. Plug Valves

1. Plug valves shall conform to the following requirements:
 - a. Plug valves shall be of the non-lubricated, eccentric type designed for a working pressure of 175 psi for valves 12-inches and smaller, 150 psi for vales 14-inches and larger.

- b. Valves shall provide tight shut-off at rated pressure.
- c. The plug valve body shall be cast iron ASTM A126 Class B with a welded-in overlay of not less than 90% nickel alloy content on all the surfaces contacting the face of the plug.
- d. The valve plug shall be constructed of cast iron conforming to ASTM A126 Class B, with Buna N resilient seating surface to mate with the body seat.
- e. Valve flanges shall be in accordance with ANSI B16.1 Class 125.
- f. Shaft bearings shall be sleeve-type, sintered, oil impregnated, and permanently lubricated stainless steel.
- g. Plug valve shaft seals shall be of the multiple V-ring type and shall be adjustable. Sealing system shall conform to AWWA C504 and C507 standards. All packing shall be replaceable without removing the bonnet or actuator and while valve is in service.
- h. Valves 6-inches and larger shall be provided with gear actuators.
- i. Provide levers or hand wheels to operate the valve as recommended by the manufacturer.
- j. Full ported (i.e., 100% flow area) and piggable.

D. Swing Check Valves

1. Swing check valves shall conform to AWWA C508 and to the following requirements:
 - a. Provide lever and weight for swing check control. Cushioned checks shall be provided where deemed necessary by the Town.
 - b. Resilient material to metal seat construction.
 - c. Ends shall be flanged.
 - d. All interior iron surfaces shall be coated with a minimum of a 8 mils of fusion bonded epoxy or liquid epoxy in accordance with ANSI/AWWA C550.

E. Air Valves

1. Air valves shall be in conformance with AWWA C512 and the following:
 - a. Valve type shall be a combination valve.
 - b. Orifices shall be sized based on system conditions and manufacturer's recommendation.
 - c. Valve shall be designed for the following automatic operation:
 - 1) Release of large quantities of air during the filling of the main.
 - 2) Permit air to enter the main when it is being emptied.
 - 3) Release accumulated air while the main is in operation and under pressure.
2. Valve shall be designed for a system pressure 150 psi. Valve shall also operate at a minimum system pressure of 20 psi.
3. Provide threaded inlet.
4. Provide 2-inch bronze ball valve.
5. Provide stainless steel ball float and wetted internal parts.

6. Provide tapping saddle and corporation stop for connection to main line.
7. For sewage force mains provide tall body to minimize possibility of sewage plugging orifice or linkage.
8. Sewage force main valve shall include backwash accessories. They shall include bronze flushing ball valves and 5 feet of rubber hose with quick-connect coupling on each end.

F. Valve Box

1. Valve boxes shall be high strength cast iron of the telescopic type. Box shall consist of a base section, center extension as required, and a top section with cover marked "SEWER."

2.06 WASTEWATER PUMP STATION

A. General

1. The requirements for individual pump stations shall be reviewed by the Town on a case by case basis. In general, pump stations shall be of the duplex, submersible non-clog centrifugal pump type. Other types of pumps may be approved by the Town. The Contractor and Engineer must provide supporting documentation as to why the alternate pumps should be used.
2. Spare pump and motor for each pump station shall be provided and delivered to the Town at a location designated by the Town.
3. Electrical requirements including the control panel will also be reviewed on a case by case basis. Adjustments to the requirements listed below and on the Standard Details will be made as deemed appropriate by the Town.

B. Pump

1. Pumps shall be submersible, non-clog, centrifugal pumps specifically designed for the specified use. Openings and passages of pump shall permit passage of the specified 3" sphere diameter and typical trash and stringy material associated with sanitary sewage. Pump with appurtenances shall be capable of continuous operation at required submergence depth. Pump shall be designed for remote connection to a base elbow using one or two guide bars.
2. Casing: Pump casing shall be constructed of cast iron ASTM A-48, Class 30. The casing shall be of uniform quality, surface, and free from defects. The casing shall be capable of withstanding operating pressures 50 percent greater than the maximum operating pressure. Volute shall have smooth passages, which provide unobstructed flow through the pump.
 - a. Mating Surfaces: Mating surfaces where watertight seal is required shall be machined and fitted with nitrile rubber O-rings. Fitting shall be such that sealing is accomplished by metal-to-metal contact between mating surfaces, resulting in proper compression of the O-rings without the requirement of specific torque limits.
 - b. Exterior Surfaces shall have a factory applied sewage resistant coating shall protect exterior surfaces of the casing in contact with sewage. Exposed nuts and bolts shall be stainless steel.
3. Impeller: Impeller shall be of cast iron and shall be of the single or double shrouded non-clogging design. Impeller shall be statically, dynamically, and hydraulically balanced. Impeller shall be securely keyed to the shaft with a

locking arrangement whereby the impeller cannot be loosened by torque from either forward or reverse direction.

4. Renewable wearing rings shall be provided on the impeller and casing and shall have wearing surfaces normal to the axis of rotation. Wear rings shall be constructed of bronze or stainless steel. Wearing rings shall be designed for ease of maintenance and shall be adequately secured to prevent rotation.
5. Shaft shall be a one piece 416 Stainless steel shaft of adequate strength to transmit full motor horsepower to the impeller.
6. A tandem mechanical shaft seal system running in an oil bath shall be provided. Seals shall be of tungsten carbide alloy with each interface held in contact by its own spring washer.
7. Pump shall rotate on a minimum of two (2) permanently lubricated bearings with a L-10 bearing life of 40,000 hours.

C. Motor

1. Provide sealed squirrel cage induction motor for submersible operation in conformance with NEMA standards for type motor specified and shall meet the following requirements:
 - a. UL listed for Class I, Division 1, Group C and D explosion proof hazardous locations.
 - b. Service factor of 1.15.
 - c. Horsepower, RPM, voltage and phase shall be as required for the specific application. Nameplate horsepower rating shall not be exceeded by the brake horsepower requirements of the specified head and capacity conditions.
 - d. Continuous duty submerged and 15 minutes in air at nameplate horsepower and a minimum of 15 evenly spaced starts per hour.
 - e. Exterior hardware shall be stainless steel.
 - f. Class F insulation.
 - g. Lifting lugs of adequate strength to lift the pump and motor assembly shall be cast into the motor housing.
 - h. Two moisture detector probes to detect seal failure shall be wired internally to control cable.
 - i. Two normally closed automatic reset thermostats shall be imbedded in the motor windings to open on excessive heat stopping the motor.
 - j. Provide waterproof power and control cable sized to conform to NEC and ICEA standards and adequate length to connect to the control panel. Seal cables at motor entry point to prevent moisture from entering motor housing and cable wicking.
 - k. Motor shall not overload throughout the pump-operating curve.

D. Painting

1. Exterior surface of pump and motor shall receive as a minimum the following paint system at the factory:
 - a. SSPC-SP6, Commercial Blast Cleaning

- b. One coat of Modified Alkyd Enamel to a minimum 2 mils dry film thickness.

E. Installation System

1. Provide a rail mounted installation system consisting of stainless steel guide rails, upper rail guide bracket, sliding bracket, intermediate rail guide bracket(s) (for rails over 20 ft), and a discharge connection elbow. System shall be of the size and type standard with the pump manufacturer for pump type to be supplied and shall not be used to support the weight of the pump. Stainless steel sliding guide bracket shall be an integral part of the pump unit. Discharge connection elbow and piping shall be permanently installed in the wet well. Pump shall be automatically connected to the discharge connection elbow when lowered into place and shall be easily removed for inspection and service without entering the wet well.
2. Provide a stainless steel lifting cable capable of supporting the pump and to raise and lower the pump through one continuous motion with the hoist.
3. All bolts to be stainless steel.

F. Control System

1. A duplex pump control panel shall be provided with, as a minimum, the required contacts and relays for the following pump operation and controls.
 - a. "Lead" pump shall start when liquid level rises to "lead pump" elevation.
 - b. If during "lead" pump operation liquid level continues to rise, "lag" pump shall start at "lag pump" elevation and operate with "lead" pump until liquid level drops to "pump off" elevation.
 - c. If liquid level continues to rise to "high water" elevation, the high water alarm shall be activated.
 - d. Pumps shall alternate between starting cycles. In the event either pump fails to function, the other shall automatically start.
 - e. Adjustable float switches shall control liquid level elevations.
 - f. Motors shall automatically shut down upon loss of phase, under voltage, or phase reversal.
 - g. Provide time delay start (15 sec) for lag pump motor to prevent both motors from attempting to start simultaneously while on standby generator power.
2. Control panel shall be a NEMA 4X stainless steel enclosure with a dead front with a hinged inner door. Panel shall be UL labeled, as a complete unit, following assembly. Panel shall include, but not be limited to, the following items:
 - a. Enclosure door shall be provided with stainless steel clamps and provisions for padlocking or shall be equipped with a three-point latching mechanism operated by an oil-tight key-locking handle.
 - b. Main circuit breaker with external operator.
 - c. Surge arrester.
 - d. Surge capacitor.

- e. Phase monitor relay (3-phase installation).
- f. Entry alarm to detect unauthorized attempt to gain entry into control panel. Provide override for use of authorized personnel.
- g. A thermal / magnetic circuit breaker and magnetic starter with 3-leg overload protection for each pump. Provide one normally open and one normally closed set of auxiliary contacts on each starter. Contacts shall be in addition to those required for specified control functions.
- h. Reduced voltage solid state soft starters:
 - 1) The solid state reduced voltage starter shall be coordinated with the starting and running characteristics of the motor driven load to ensure a complete and operable system. Coordination between the motor control manufacturer and the mechanical equipment supplier is essential and required to ensure that speed-torque requirements are met. Specifically, the motor controller shall provide enough voltage at the time of start and produce enough torque to start the load while maintaining the desired results of a reduced voltage start.
 - 2) Starter shall be installed in control panel.
 - 3) The motor shall be protected from solid state component failure by an isolation contactor that opens when the motor is stopped or when the controller detects a fault condition including a shorted SCR.
 - 4) The soft start shall provide torque control for linear acceleration independent of motor load in a manner to ensure a stable and linear acceleration ramp.
 - 5) A shorting contactor shall be provided. The shorting contactor shall close, shorting the SCRs after the acceleration ramp is complete and open on a stop command to allow a deceleration ramp.
 - 6) The soft start shall be capable of supplying 400% of rated full load current for 23 seconds at maximum ambient temperature.
 - 7) A digital keypad shall be provided to enter operating parameters.
 - 8) A full voltage bypass starter with overload protection shall be included to provide motor operation in the case of soft starter failure. A NORMAL/BYPASS selector switch shall be provided.
 - 9) Should pump/motor require a 460 V installation, provide a transformer sized for control circuit loads and additional 120 V circuits as required. Transformer size shall be adequate to provide 150 percent of the control circuit requirements, a minimum of 3.5 amperes for the receptacle and 100 percent of other auxiliary 120-volt loads. Provide fused primary and secondary and bond unfused leg of secondary to enclosure.
- i. Obtain control circuit voltage between one of the phase conductors and neutral. On high leg systems, the selected phase must be one of the non-high leg phases.
- j. Separate circuit breaker with handle to project through inner door for the following:
 - 1) Each pump motor
 - 2) Control circuit.

- 3) Cabinet heater.
- 4) Door mounted duplex receptacle.
- 5) Battery charger receptacle.
- k. Cabinet condensate heater with thermostat.
- l. Alternator relay to alternate pumps between successive starts.
- m. Mount the following devices on inner door:
 - 1) Hand-off-automatic (H-O-A) control switch for each pump.
 - 2) Non-resettable elapsed time meter for each pump. Meter shall read in tenth of hours through 99,999 hours total time.
 - 3) GFCI type duplex receptacle.
- n. Mount operating and warning lights on inner door for the following. Color indicates required lens color.
 - 1) Power on (white).
 - 2) High water level (red).
 - 3) For each pump.
 - i. Running (green).
 - ii. Seal failure (red).
 - iii. Thermal overload (red).
 - iv. Soft start failure (red).
 - 4) Phase monitor (red).
 - 5) Generator failure (red).
- o. Alarm horn and light (red) mounted on top of protective shield. Horn sound level shall be a minimum of 100 decibels at 10 feet. Provide horn silence switch on inside panel.
 - 1) In the event of a power loss at the pump station or a failure of the automatically activated stand-by generator, the alarm system shall be operated from a battery back-up power source. Battery back-up power source shall be provided with continuous charge. No alarm relays or indicator lights (except the alarm silence relay and alarm light) shall be part of the battery charging circuit.
 - 2) At a minimum, the following conditions shall be monitored by the system, and each shall cause activation of the audible and visual alarms:
 - i. Loss of power supply.
 - ii. Pump failure for each pump for seal failure or thermal overload.
 - iii. High water level.
 - iv. Loss of telemetry transmission line. Provide contacts for signal from telemetry system.
 - v. Standby generator failure.

- p. Auxiliary contacts for remote signal for the following:
 - 1) Pump run status for each pump.
 - 2) High water alarm.
 - 3) Pump failure alarm for both pumps on thermal overload or seal failure.
 - 4) Loss of power.
 - 5) Loss of phase to indicate over / under voltage, phase loss, or phase reversal.
 - 6) Standby generator failure.
 - 7) Generator low fuel.
 - 8) Generator run status.
 - q. Provide laminated plastic labels to identify all control components.
 - r. Provide a plastic laminated electric diagram with wire / terminal numbers and color codes permanently fastened to inside of enclosure door.
3. Switches, push buttons, and indicator lights shall be 30.5 mm oil tight / watertight units. Lights shall be LED push-to-test type.
 4. Wire shall be sized as required for load and application according to NEC. Wiring shall be neatly bundled and continuous from point to point. Wiring shall be totally accessible with permanent marking on each end to match the schematic drawing. Control and signal wire shall be a minimum of #14 AWG, stranded, 90 degree insulated and color-coded. Color coding shall be as follows:
 - a. RedAC control
 - b. BlueDC control
 - c. YellowExternal source control
 - d. WhiteAC neutral
 - e. GreenGround
 5. Provide UL listed mercury float switches encapsulated in buoyant waterproof housing with sufficient cable to extend to control panel. Float and cable shall be designed and manufactured for use in a sewage wet well environment. Sensor levels shall be field adjustable.
 6. Conduits running into wet well shall have a positive seal in accordance with NFPA 70.

G. SCADA

1. SCADA will be provided for all new pump stations.
2. Type of system and monitored conditions shall be consistent with the existing system in use by the Town at the time the new pump station is constructed.
3. Design of the system shall be closely coordinated with the Town and require prior written approval by the Town.

H. Portable Hoist

1. Provide one galvanized or stainless steel portable hoist at each pump station with reach as required for the safe removal of each pump.
2. Hoist shall have a capacity of 150 percent of equipment weight and capable of 360 degree rotation.
3. Hoist shall have winch with quick disconnect cable anchor for receiving stainless cable with swagged ball end.
4. Electric winch shall be provided on hoist.
5. Provide lifting cable for each pump. Lifting cable shall be stainless steel with snap hook on pump end and swagged ball on winch end. Cable shall have sufficient length to reach from installed equipment to lifting winch.
6. Provide number of floor mounted stainless steel sockets at each pump station as required for the removal of the equipment.
7. Portable hoist shall be as manufactured by Halliday Products, Thern Inc., or Wallace B E Products.

I. Pressure Gauges

1. Pressure gauges shall meet the following requirements:
 - a. Use:..... Pressure reading for sanitary sewer force main
 - b. Liquid Fill: Glycerin
 - c. Dial: White aluminum with black markings
 - d. Dial Size: 4-inch minimum
 - e. Case & Ring: Aluminum
 - f. Accuracy: 1/2% of full scale (Grade 2A)
 - g. Stem Connection: Back
 - h. Gauge Reading: Combination reading in psi and feet of water (ft) with range as appropriate for system pressure.
 - i. Equipped with a stopcock and a diaphragm isolator for use with sewage.
 - j. Mounted on piping in the valve box. Provide accessories as necessary so gauge shall face up with numbers reading towards access hatch.
2. Provide a 1/4-inch tap on each effluent pipe for pressure gauge.

J. Pre-Cast Concrete Wet Well and Valve Vault

1. Pre-cast concrete wet wells and valve vaults shall be in conformance with the requirement for pre-cast concrete manholes with the following exceptions:
 - a. Tops shall be flat.
 - b. Tops of wet wells and valve vaults shall be a minimum of 2 feet above the 100 year flood elevation.

- c. Steps are not required.
- d. Ring and covers shall be replaced with access hatches as described herein.
- e. Floor drain, trap and backwater valves shall be provided and sized per the Standard Detail and meet current NC plumbing codes.

K. Access Hatch

- 1. Hatches shall be sized and located to facilitate the easy removal of pumps, motors, valves and other items from the wet wells and valve vaults. They shall meet the following requirements:
 - a. Frame shall be aluminum extrusion and aluminum checkered tread plate for the door(s). Frame shall be equipped with necessary anchors for setting in concrete. Hinges, nuts, bolts, and washers shall be stainless steel and tamper proof from outside.
 - b. Design and construct hatches for a minimum 310 lb. live load unless an H2O load is anticipated.
 - c. Provide the following:
 - 1) Bituminous coating at locations, which will have contact with concrete.
 - 2) Waterproof hatch unless flood-tight hatch required by the Town.
 - 3) Positive open door latch.
 - 4) Retractable lifting handle.
 - 5) Double doors shall be interlocked.
 - 6) Padlocking provision. Provide lock for each hatch and keyed alike for multiple hatches.
 - 7) Provide doors requiring greater than a 50 lb lift with a stainless steel spring assist.
- 2. Hatches shall be of one manufacturer.

L. Safety Net

- 1. Pump access hatches shall be provided with a rail mounted safety net system for fall through protection. The safety net shall be designed to slide on guide rails to facilitate entry and repositioning. Slide rails and hooks shall be constructed of aluminum with stainless steel corner hooks and eye bolts. Netting material shall be polyester. The safety net system shall be hatch net as manufactured by Safe Approach, Inc., or approved equal.

M. Yard Hydrant

- 1. Provide a non-freeze, self draining, post type yard hydrant with lever handle operator. Interior parts and casing shall be bronze with cast aluminum casing guard. Seat washer shall be replaceable. Drain port shall be a minimum of 1/8-inch diameter. Hydrants shall have a 3/4-inch hose bib and a 3/4-inch inlet. See water details for yard hydrant detail.

N. Quick Connect Coupling

- 1. A male quick connect coupling is required on end of by-pass pipe within valve vault. The size and compatibility shall be the same as what is currently utilized by the Town.

O. Sign

1. Pump stations shall have a metal sign mounted on the fence at the gate to the pump station. Sign shall be a minimum of 18-inches square and white with blue lettering. Sign shall read "Town of Granite Falls Wastewater Pump Station, Name of Pump Station, Emergency Contact Phone Number."

2.07 ENGINE GENERATOR SYSTEM WITH AUTOMATIC TRANSFER SWITCH

A. General

1. Each new sewer pump station shall be provided with an on-site engine generator system including an automatic transfer switch to provide emergency back-up power. The generator shall be rated to continuously provide power for both pumps and all associated equipment simultaneously for the duration of any normal power failure as determined by the Town. In no case shall the fuel storage be less than that needed to operate the generating unit for 12 continuous hours.
2. Each generator system will be evaluated on a case by case basis with adjustments to the requirements as stated herein as deemed appropriate by the Town.
3. Approved manufacturers of the engine generator set are as follows:
 - a. MTU-On Site Energy
 - b. Onan
 - c. Caterpillar
 - d. Olympian
 - e. General
 - f. Kohler
4. Approved manufacturers of the automatic transfer switch are:
 - a. Russelectric
 - b. GE/Zenith
 - c. Asco
 - d. Lake Shore
 - e. Standard product of the generator set manufacturer.

B. Engine

1. Engine requirements include the following:
 - a. Water-cooled inline or V-type, four stroke cycle, compression ignition Diesel internal combustion engine.
 - b. Rating: 100 percent of rated Kw for duration of an emergency outage.
 - c. Isochronous type governor to maintain engine speed within 0.5 percent, steady state, and 0.5 percent, no load to full load, with recovery to steady state within 2 seconds following sudden load changes. Equip governor with means for manual operation and adjustment.

- d. Automatic engine shutdown on high coolant temperature, low oil pressure, overspeed, and engine overcrank. Limits as selected by manufacturer.
- e. DC engine starting system with positive engagement, number and voltage of starter motors as required by manufacturer. Include remote starting control circuit, with Run-Off-Auto selector switch on engine / generator control panel.
- f. Include a thermal circulation type water heater with integral thermostatic control, sized to maintain engine jacket water at 90 degrees F.
- g. Unit mounted radiator using glycol coolant, with blower type fan. Size fan to maintain safe engine temperature in ambient temperature of 110 degrees F with a maximum of 0.5 inches of water static pressure on the fan.
- h. Engine Accessories: Fuel filter, lube oil filter, intake air filter, lube oil cooler, fuel transfer pump, fuel priming pump, gear driven water pump, and gear type lube pump. A bypass valve shall be provided to allow lube oil circulation in the event of a failure of the filtering system.
- i. Provide vibration isolators between engine/alternator and base frame.

C. Generator

1. Generator requirements include the following:
 - a. NEMA MG1 three phase, four pole, re-connectable brushless synchronous generator with brushless exciter, twelve lead, 2/3 pitch, random wound, permanent magnet generator.
 - b. Alternator Insulation Class: H.
 - c. Temperature Rise: Class F. 130 degrees C rise @ 40 degrees C ambient (Standby duty).
 - d. Enclosure: NEMA MG1, open drip proof.
 - e. Include generator-mounted volts per hertz exciter-regulator to match engine and generator characteristics, with voltage regulation plus or minus 1 percent from no load to full load. Include manual controls to adjust voltage droop, voltage level (plus or minus 5 percent) and voltage gain.
 - f. Frequency Regulation: 3 hertz maximum from no load to rated load.
 - g. Anti-Condensation space heater.
 - h. Diesel engine generator systems shall meet or exceed the emission requirements of the current Environmental Protection Agency regulations for emergency generators.
2. Accessories
 - a. Critical type silencer with muffler companion flanges and flexible stainless steel exhaust fitting, sized in accordance with engine manufacturer's instructions. The silencer shall be mounted within the generator enclosure. The silencer shall be industrial standard construction, all welded, for stationary engine application. The entire exhaust system shall be supported independently of the generator set to prevent transmission of vibration and allow for thermal expansion. Long radius,

low restriction fittings shall be used throughout, and pipe size shall be sufficiently large to handle the engine exhaust flow at full load without causing back pressure in excess of that allowed by the engine manufacturer. A stainless steel rain cap shall be provided.

- b. Batteries: Heavy duty, diesel starting type lead-acid storage batteries of sufficient capacity to provide a minimum of five full cycle starts for ten seconds crank with ten second rest periods between cranks. Match battery voltage to starting system. Include necessary cables and clamps.
- c. Battery Tray: Treated for electrolyte resistance, constructed to contain spillage.
- d. Battery Charger: Current limiting type designed to float at 2.17 volts per cell and equalize at 2.33 volts per cell. Include overload protection, full wave rectifier, DC voltmeter and ammeter, and 120 volts AC fused input. Provide enclosure to meet NEMA 250, Type 1 requirements and NFPA 110 requirements.
- e. Line Circuit Breaker: NEMA AB 1, molded case circuit breaker on generator output with integral thermal and instantaneous magnetic trip in each pole. Unit-mount in enclosure to meet NEMA 250, Type 1 requirements.
- f. Control Panel: NEMA 250, Type 1 generator mounted control panel enclosure with engine and generator controls and indicators conforming to NFPA 110 Level 2. Panel shall be mounted with vibration isolators. Unit shall include the following devices and features:
 - 1) Panel lighting.
 - 2) Fused DC circuit to protect controls.
 - 3) 3-position Run - Off – Auto selector switch.
 - 4) Frequency Meter: 45-65 Hz. range, 3.5-inch dial (or digital display).
 - 5) AC Output Voltmeter: 3.5-inch dial, 2 percent accuracy, with phase selector switch (or digital display).
 - 6) AC Output Ammeter: 3.5-inch dial, 2 percent accuracy, with phase selector switch (or digital display).
 - 7) Output voltage adjustment.
 - 8) Provide indicator lights to show the following:
 - i) Generator Off (Red)
 - ii) Generator Auto (Green)
 - iii) Generator Run (Yellow)
 - iv) Generator Warning (Yellow)
 - v) Generator Shutdown (Red)
 - 9) Provide a scrolling digital display or indicator light to show the following critical data:
 - i) Overcrank. (Shutdown)
 - ii) Low water temperature. (Shutdown)
 - iii) High engine temperature.(Shutdown)

- iv) Low lube oil pressure.(Shutdown)
 - v) Overspeed.(Shutdown)
 - vi) Low coolant level warning.
- 10) Audible alarm for any of the above conditions. Provide silence switch; however, activation shall not inhibit any subsequent alarms from sounding.
 - 11) Engine running time meter.
 - 12) Oil pressure gauge.
 - 13) Coolant temperature gauge.
 - 14) Emergency stop switch.
 - 15) Auxiliary Relay for indicating that generator set is running or shut down, with contact terminals prewired to terminal strip.
 - 16) Common Failure Relay: Remotely signals auxiliary fault, emergency stop, high engine temperature, low oil pressure, overcrank and overspeed.
 - 17) Provide terminal strip for remote signaling of alarm and status to SCADA. Coordinate with Town as to which conditions are to be monitored.
 - 18) Signal to fuel shut-off solenoid valve on fuel supply line to open when required by the generator.
3. Weather Protective Enclosure
- a. Sound attenuated Level 1 reinforced aluminum housing allowing access to control panel and service points, with lockable doors and panels. Sound pressure level shall be limited to 76 dBA at 7 meters. Include fixed louvers, battery rack, battery charger rack, and silencer. Doors shall be equipped with stainless steel locks and hinges. Provide oil and coolant drain extensions. Color shall be manufacturer's standard.
4. Sub-Base Fuel Tank
- a. Fuel system shall include a double walled, UL approved, welded construction, base mounted fuel tank with integral stub-up area. It shall have the structural integrity to support the engine generator set. The tank must be supplied and warranted by the engine generator set manufacturer and be factory installed. Minimum features shall include:
 - 1) Lockable fuel filler cap. Shall be installed in a 5 gallon spill containment reservoir with drain and lockable cover.
 - 2) Fuel gauge.
 - 3) Low fuel level alarm.
 - 4) Tank rupture alarm.
 - 5) Fuel line check valve.
 - 6) Fittings for fuel supply, return, fill and vent.
5. Access Platform
- a. If height of fuel tank exceeds 30 inches above top of generator pad, the Contractor shall provide an all welded steel structural platform with

walkway floor even with bottom of generator skids. Steps shall meet OSHA requirements. A 42 inch wide walkway with aluminum pressure locked grating shall extend all around the generator set. Grating shall be flush top SGF Series by Ohio Gratings Inc., or equal. Bearing bar spacing shall be on 1-3/16 inch centers. Cross bars shall be locked at right angles to, and in the same plane as the top surface of bearing bars. Spacing shall be 4 inches on center. Grating shall be supported on minimum 4 foot centers. Grates shall have an anti-skid surface and shall be designed to support a live load of not less than 200 pounds per square foot with a maximum deflection of 1/180th of the span. A double pipe 42 inch handrail system consisting of 1-1/2 inch diameter aluminum pipe for the rails and vertical posts, and toe plate, shall be provided on the outside perimeter and rails shall be provided on each side of the steps. The platform location shall not interfere with tank fill operations. Color to be selected by owner. Aluminum components shall not be painted. Access platform fabricator shall submit shop drawings with detailed connections and structural calculation sealed by registered North Carolina Structural Engineer.

6. Duplex Receptacle

- a. Provide a GFCI type duplex convenience receptacle inside the weatherproof enclose. Receptacle shall be connected to an external circuit.

7. Emergency Stop Switch

- a. Heavy duty, red mushroom push bottom, push-to-stop/pull-to-activate maintained contacts, mounted in NEMA Type 12 enclosure. Provide phenolic label attached to enclosure stating, "GENERATOR EMERGENCY STOP".

D. Automatic Transfer Switch

1. Transfer switch requirements include the following:

- a. NEMA ICS 10 closed transition automatic transfer switch, service entrance rated with integral overcurrent protection for both sources.
- b. Electrically operated, mechanically held transfer switch.
- c. Time delay neutral transfer method.
- d. Ground fault protection shall be provided on overcurrent protective device.
- e. Provide lights mounted in cover of enclosure to indicate Normal Source Available, Alternate Source Available and Switch Position.
- f. Mount test switch in cover of enclosure to simulate failure of normal source.
- g. Provide Transfer Switch Auxiliary contacts as follows:
 - 1) One set of relay contacts to open on loss of normal power supply.
 - 2) One set of relay contacts to close when switch in "NORMAL" position.
 - 3) One set of relay contacts to close when switch in "EMERGENCY" position.

- 4) One set of relay contacts for generator "RUN".
 - 5) One set of relay contacts for generator "FAIL".
 - 6) One set of relay contacts interlocked with the pump control panel to open when the switch is in the emergency position to lock out the lag pump.
 - h. Normal Source Monitor: Monitor each line of normal source voltage and frequency; initiate transfer when voltage drops below 80 percent or frequency varies more than 5 percent from rated nominal value.
 - i. Thermostatically controlled electric heater sized to prevent condensation under expected weather conditions at the project site. Provide terminals for separate connection of 120 volt power.
2. Automatic Sequence of Operation
- a. Initiate Time Delay to Start Alternate Source Engine Generator: Upon initiation by normal source monitor.
 - b. Time Delay To Start Alternate Source Engine Generator: 0 to 3 seconds, adjustable.
 - c. Initiate Transfer Load to Alternate Source: Upon initiation by normal source monitor and permission by alternate source monitor.
 - d. Time Delay Before Transfer to Alternate Power Source: 0 to 3 seconds, adjustable.
 - e. Initiate Retransfer Load to Normal Source: Upon permission by normal source monitor.
 - f. Time Delay Before Transfer to Normal Power: 0 to 25 minutes, adjustable; bypass time delay in event of alternate source failure.
 - g. Time Delay Before Engine Shut Down: 0 to 25 minutes, adjustable, of unloaded operation.
 - h. Engine Exerciser: Start engine every 7 days; run for 30 minutes before shutting down. Bypass exerciser control if normal source fails during exercising period.
 - i. Alternate System Exerciser: Transfer load to alternate source during engine exercising period.
3. Enclosure
- a. Enclosure: ICS 6, Type 1.
 - b. Finish: Manufacturer's standard gray enamel.

PART 3 EXECUTION / INSTALLATION

3.01 PIPE AND ACCESSORIES

A. General

1. Provide erosion control measures as required. Erosion control measures including seeding and mulching shall be designed, installed and maintained in accordance with the N.C. Department of Environment and Natural Resources, Land Quality Section's "Erosion and Sediment Control Planning and Design

Manual". The Contractor and Engineer is responsible for securing all required permits.

2. Pipe installation shall meet the following general guidelines:
 - a. Handle pipe and accessories in accordance with manufacturer's recommendations. Take particular care not to damage pipe coatings.
 - b. Carefully inspect pipe immediately prior to laying. Do not use defective pipe. Replace pipe damaged during construction.
 - c. Lay pipe to design grade and alignment.
 - d. Provide proper equipment for lowering pipe into trench.
 - e. Provide tight closure pipe ends when work is not in progress.
 - f. Keep pipe interior free of foreign materials.
 - g. Do not lay pipe in water or when the trench or weather conditions are unsuitable for the work.
 - h. Clean bell and spigots before joining. Make joints and lubricate gasket in accordance with pipe manufacturer recommendation.
 - i. Block fittings with concrete or restrained joints.

B. Trenching for Underground Pipe Installation

1. Definitions

- a. Backfill: A specified material used in filling the excavated trench and placed at a specified degree of compaction.
 - 1) Materials: Materials listed herein include processed materials plus the soil classifications listed under the Unified Soil Classification System, (USCS) (Method D2487 and Practice D2488). The soil materials are grouped into five broad categories according to their suitability for this application.
 - i. Class I: Angular, 6 to 40-mm (1/4 to 1-1/2-in.), graded stone, including a number of fill materials that have regional significance such as coral, slag, cinders, crushed stone, and crushed shell.
 - ii. Class II: Coarse sands and gravels with maximum particle size of 40 mm (1-1/2 in.), including various graded sands and gravels containing small percentages of fines, generally granular and noncohesive, either wet or dry. Soil Types GW, GP, SW, and SP are included in this class.
 - iii. Class III: Fine sand and clayey gravels, including fine sands, sand-clay mixtures, and gravel-clay mixtures. Soil Types GM, GC, SM, and SC are included in this class.
 - iv. Class IV: Silt, silty clays, and clays, including inorganic clays and silts of medium to high plasticity and liquid limits. Soil Types MH, ML, CH and CL are included in this class. These materials shall not be used for bedding, haunching, or initial backfill.
 - v. Class V: This class includes the organic soils OL, OH, and PT as well as soils containing frozen earth, debris, rock larger than 40 mm (1 1/2 in.) in diameter, and other foreign

materials. These materials shall not be used for bedding, haunching, or initial backfill.

- 2) Backfill Zones: Each backfill zone shall extend the full width of the trench bottom.
 - i. Foundation: Extending down from the bottom of bedding zone as defined below.
 - ii. Pipe Embedment
 1. Bedding: Extending from 4 inches below the pipe bottom to the pipe bottom for 30-inch diameter and smaller and 6 inches below the pipe bottom for pipes larger than 30 inches in diameter.
 2. Haunching: Extending from the bedding (bottom of the pipe) to the pipe spring line.
 3. Initial Backfill: Extending from the haunching (pipe spring line) to 1 foot above the top of the pipe.
 - iii. Final Backfill: Extending from the initial backfill to the finish ground elevation.
- b. Laying Conditions:
 - 1) Type 1: Flat bottom trench with loose backfill.
 - 2) Type 2: Flat bottom trench with backfill lightly consolidated to centerline of pipe.
 - 3) Type 3: Pipe bedded in 4 inches minimum of loose soil and backfill lightly consolidated to top of pipe.
 - 4) Type 4: Pipe bedded on Class I material to 1/8 pipe diameter (4 inch minimum) Backfill compacted to top of pipe a minimum of 80 percent of standard proctor.
 - 5) Type 5: Pipe bedded in compacted Class I material to pipe centerline with 4-inch minimum under pipe. Backfill to top of pipe with Class I, II, or III and compact to 90 percent of standard proctor.
- c. Compaction: Process of mechanically stabilizing a material by increasing its density at a controlled moisture condition. "Degree of compaction" shall be expressed as a percentage of the maximum dry density obtained by the test procedure presented in ASTM D698 (Standard Proctor).
- d. Excavation: The removal of soil or rock to obtain a specified depth or elevation.
- e. Hard Material: Solid, homogeneous material which is not included in the definition of "rock" but which may require the use of heavy excavation equipment with ripper teeth. Amount must exceed 1 cubic yard in volume. Material having a standard penetration resistance as determined by ASTM D1586 between 60 and 150 blows per foot is defined as "hard material."
- f. Lift: Layer of soil placed on top of a previously prepared or placed soil.
- g. Rock: Solid, homogeneous material which cannot be removed without the systematic drilling and blasting exceeding 1 cubic yard in volume. Material having a standard penetration resistance as determined by

ASTM D1586 greater than 150 blows per foot is defined as "rock." Removal of "hard material" will not be considered rock excavation because of intermittent drilling and blasting that is performed merely to increase production.

- h. Pipe Springline: A line running horizontally through the center of the pipe.
- i. Topsoil: Natural, friable soil, representative of productive soils in the vicinity of the site. Topsoil shall be free from roots, stones larger than 1 inch, objectionable weed seeds, toxic substances, and materials that hinder grading, planting, and maintenance operations.

2. Products

a. Stone

- 1) Class I material shall be #67 or #78M stone in accordance with NCDOT specifications Section 1005, General Requirements for Aggregate.

b. Warning and Identification Tape

- 1) Tape shall be a minimum 3-inch wide polyethylene plastic tape manufactured specifically for identification of buried utilities with means of enabling detection by a metal detector to a minimum depth of 3 feet. Tape shall be color coded and continuously imprinted with warning and identification markings in bold black letters to read "CAUTION - BURIED (utility) LINE BELOW." Color and printing shall be permanent, unaffected by moisture or soil and shall be as follows:

UTILITY	COLOR	MARKING
Water	Blue	Caution - Buried Water Line Below
Gravity Sewer	Green	Caution - Buried Sewer Line Below
Force Main.....	Green	Caution - Buried Force Main Below
Electric.....	Red	Caution - Buried Electric Line Below
Gas	Yellow	Caution - Buried Gas Line Below
Telephone.....	Orange	Caution - Buried Telephone Line Below
SCADA	Orange	Caution - Buried SCADA Line Below

- 2) Tape shall be by Blackburn Manufacturing, Joseph G. Pollard Co., or Reef Industries Inc.

c. Tracer Wire

- 1) Tracer wire shall be #12 solid copper wire. All connections shall be by wire nuts and taped.
- 2) Splices in tracer wire are to be kept to a minimum and joined with copper split nuts of appropriate size.
- 3) Tracer wire shall be installed on all mains and services.

3. Project Safety

- a. Contractor is responsible for Project safety.

- b. Perform work in conformance with applicable State and Federal safety regulations including, but not limited, to the following:
 - 1) North Carolina Safety and Health Standards for the Construction Industry (29CFR 1926 Subpart P).
 - 2) NC OSHA Industry Guide No. 14, Excavations.
 - 3) NC OSHA Industry Guide No. 20, Crane Safety.
 - c. Provide barriers, warning lights, and other protective devices at excavations as necessary for safety of workers and the public.
 - d. Provide sloping of bank, shoring, sheeting, or other means of maintaining the stability of the trench in accordance with the requirements of the Associated Contractor's Manual of Accident Prevention OSHA, Part 1926.P.
4. Protection of Underground Facilities
- a. Investigate underground facility location prior to start of construction.
 - b. Installer is required to contact North Carolina 811 prior to start of construction.
 - c. Repair damage to any existing facilities.
5. Water Control
- a. Prevent surface water from entering the trench.
 - b. When trench bottom is below the existing ground water table, install a dewatering system to maintain water table 1 foot below trench bottom. Provide a man experienced in dewatering work at the job site.
 - c. Maintain dewatering until backfilling has proceeded above the existing ground water level.
 - d. Dispose of water from dewatering operations in accordance with the North Carolina Sedimentation Pollution Control Act.
6. Use of Explosives
- a. Explosives may not be used on any excavation unless specifically approved by the Town. If approved by the Town, the Contractor shall be responsible for securing all required approvals and permits.
7. Excavating
- a. Excavation shall be by open cut method. Short sections of trench may be tunneled or direct bored with the approval of the Town.
 - b. Stockpile excavated material in such a manner that it will not obstruct the flow of runoff, streams, endanger Work, impair the use or appearance of existing facilities, or be detrimental to the completed Work.
 - c. Contractor shall segregate excavated material so as to maintain material suitable for backfill separate from material that is unsuitable.
 - d. Trench dimensions at the pipe embedment and foundation zone unless noted otherwise shall be as follows:
 - 1) Minimum width: Pipe outside diameter plus 18 inches.
 - 2) Maximum width: Pipe outside diameter plus 24 inches.

- 3) Sides shall be vertical to a minimum of one foot above the top of pipe.
 - e. Shape trench bedding to provide uniform bearing for the full pipe length. Bottom shall be free of protrusions that could cause point loading on pipe. Provide bell holes as required for properly making pipe joint.
 - f. Do not over excavate. Excavation below grade shall be backfilled with Class I material at no cost to the Town.
 - g. Undercut soils that become unsatisfactory by construction activity or by being left exposed to the weather and backfill with Class I material.
 - h. Remove shoring, bracing, and sheeting, unless otherwise noted, as the trench is backfilled.
 - i. Excavation of trench shall not advance more than 200 feet ahead of the installation. In no case should the excavation extend beyond that which can be backfilled by the end of the workday.
 - j. Correct unstable soil conditions encountered at trench foundation by one of the following methods:
 - 1) Excavate below grade as approved by Engineer and backfill with Class I material or approved substitute material.
 - k. Rock and Hard Material
 - 1) Excavate rock and hard material to a minimum depth of 4 inches below the pipe for pipes smaller than 30 inches and 6 inches for pipes 30 inches and larger.
 - l. Pressure Lines:
 - 1) Provide a minimum 3 feet of cover.
 - 2) Excavate trenches to provide vertical curve chords that will not exceed the pipe manufacturer's recommended joint deflection.
 - 3) Provide concrete thrust blocks having a compressive strength of 3,000 psi at 28 days at change in horizontal and vertical direction and reduction in the pipe size, unless other restraint systems are approved. Cut trench sides vertical and square to receive concrete. Provide bearing area against trench wall as indicated in the Standard Detail.
 - m. Gravity Lines:
 - 1) Excavate trench to the design alignment and grade.
 - n. Utility Structures: Provide a minimum of 12 inches below subgrade and backfill with Class I compacted to 95 percent maximum density. If the soil conditions are found to be unsuitable for structural stability of the manhole, Town may require additional depth of Class I material.
8. Backfilling
- a. General
 - 1) Temperature must be above freezing and rising.
 - 2) In windy, hot, or arid conditions with a high rate of evaporation add moisture to the material to maintain the optimum moisture content.
 - 3) Do not proceed in rain or on saturated subgrade.

- 4) Do not place material on surfaces that are muddy, frozen, or contain frost.
 - 5) Pipes of all materials shall be placed on a minimum of 4-inches of #67 stone bedding.
 - 6) Maintain backfill operation within 200 feet from pipe laying operation.
 - 7) Backfill trench to existing ground surface with select excavated material at the specified compaction.
 - 8) If excavated material is unsuitable to obtain specified compaction, provide suitable off-site borrow material for backfill.
 - 9) Re-excavate trenches improperly compacted. Backfill and compact as specified.
 - 10) Provide appropriate tamping equipment, and water to obtain proper moisture content, to achieve specified compaction of backfill.
 - 11) Conduct operation of heavy equipment above pipe installation as to prevent damage to pipe.
 - 12) Install warning / identification tape over utilities. Bury tape one foot below finished grade above the utility.
 - 13) Install tracer wire for non-metallic pressure pipe. Bury tracer wire with pipe. Wire shall be looped into valve boxes to allow access for direct contact location.
- b. Backfill in pipe embedment zone (bedding, haunching, and initial backfill).
- 1) General
 - i) Backfill with material as specified below. Material shall be free from objects larger than 1-inch.
 - ii) Where rock and hard material has been excavated below pipe bottom, backfill and compact bedding with Class I material. Class II or III material may be used for bedding with Engineer's approval.
 - iii) Place backfill material to assure placement of material under pipe haunches.
 - iv) Take care during placement and compacting of material to avoid movement of pipe.
 - 2) Place backfill in bedding and haunching zones in 6 inch maximum lifts and compact to 90 percent density. Place initial backfill in one lift do not compact. Provide backfill material in pipe embedment zone as specified below.
 - i) Pressure Lines (Flexible and Rigid Pipe)
 1. Excavation in Class I, Class II, and Class III soils suitable for bedding, the bedding surface shall provide a firm foundation of uniform density. Backfill with select excavated material.
 2. Excavation in Class IV or Class V, running water, and other unstable soil conditions, excavate a minimum of 4 inches below pipe bottom and provide Class I

material for bedding and haunch zone. Backfill with Class I, II, or III material in initial backfill.

3. Ductile Iron over 16 inch
 - a) Depth 0 - 12 feet: Type 2 laying conditions same as for pressure pipe.
 - b) Depth over 12 feet: Provide Class I material for bedding and 4 inches up from bottom of pipe.

ii) Gravity Sewer Lines, Rigid Pipe and Ductile Iron

1. Excavation in Class I, Class II, Class III, and stable Class IV soils suitable for bedding, the bedding surface shall provide a firm foundation of uniform density. Backfill with select excavated material.
2. Excavation in Class V, unstable Class IV soils, running water, and other unstable soil conditions, excavate a minimum of 4 inches below pipe bottom and provide Class I material for bedding and haunch zone. Backfill with Class I, II, or III material in initial backfill.

iii) Gravity Sewer Lines, Flexible (PVC SDR 21)

1. Depth 0 to 14 ft: Provide Class I material for bedding and haunching. Backfill with Class I, II, or III material in initial backfill.
2. Depth over 14 ft: Provide Class I material for bedding, haunching, and initial backfill.

c. Final Backfill

- 1) Backfill with materials free of stones and free of debris larger than 6 inches in dimension. Place backfill in lifts not exceeding the thickness and compacted to the minimum density specified below.
- 2) Trench backfilled with non-cohesive materials may be compacted with water flooding; except under roadways, shoulders of roadways, and other areas subject to vehicular movement, provided the method of compaction is approved by the Town and provides the degree of compaction required.
- 3) Lifts and density:
 - i) Undeveloped areas (i.e., forests, fields, and, croplands): Trench may be filled with bulldozer blade provided material fall will not damage pipe. Mound soil over the trench area sufficiently to settle level over time. Degree of compaction shall be 85 percent.
 - ii) Lawns: Backfill in 12-inch lifts and compact to 90 percent. Top 12 inches shall be free of material with a dimension over 2 inches.
 - iii) Roads (including rights-of-way), drives, parking areas (including areas within 20 feet), and adjacent to existing utilities: Backfill in 6 inch lifts compact to 95 percent.

- iv) Within 20 feet of foundations: Backfill in 6-inch lifts compacted to 95 percent.
 - d. Utility Structures: Bring backfill to grade in even lifts on all sides. Lift depths and compaction densities shall be as specified according to area of installation for pipe above. Backfill against cast-in-place concrete structure only after concrete has attained the specified 28-day compressive strength.
- C. Relation of Sewer to Water Main, Wells and Storm Sewer
 - 1. Lateral Separation: Lay at least 10 feet laterally from existing and proposed water main. Where existing conditions prevent a 10-foot lateral separation, the following shall be followed with approval of the Town:
 - a. Lay sewer in a separate trench, with the elevation of the top of the sewer at least 18-inches below the bottom of the water line.
 - b. Lay sewer in the same trench as the water main with the sewer main located at one side on a bench of undisturbed earth, and with the elevation of the top of the sewer at least 18 inches below the bottom of the water line.
 - 2. Crossing Separation: Lay top of sewer at least 18 inches below the bottom of the water. Where existing conditions prevent an 18-inch vertical separation, construct both the water main and sewer of ferrous materials and with joints that are equivalent to water main standards for a distance of 10 feet on each side of the point of crossing. Both the water and sewer line must be pressure tested to 150 psi to insure water tightness.
 - 3. Crossing a Sewer Over a Water Main: When it is necessary for a sewer to cross over a water main, construct both the water main and the sewer of ferrous materials and with joints equivalent to water main standards for a distance of 10 feet on each side of the point of crossing. A section of water main pipe shall be centered at the point of crossing.
 - 4. A 24-inch vertical separation shall be provided between sanitary sewers and storm sewers or ferrous pipe specified.
 - 5. Lay sewer pipe to true lines and grades by use of laser beam equipment or other acceptable means.
 - 6. Minimum Separation Distances:
 - a. 100-foot horizontal separation from wells or other water supplies.
 - b. 24-inch vertical separation from storm sewers or ferrous pipe shall be used.
- D. Ductile Iron Pipe
 - 1. Install pipe in conformance with AWWA C600 and the following:
 - a. For laying pipe in a vertical or horizontal curve, each full length pipe may be deflected by the following offset distance:
 - 1) Push-on joint
 - i) 3 to 12-inch pipe: 14-inch offset
 - ii) 14 to 36-inch pipe: 8-inch offset
 - 2) Mechanical joint

- i) 3 to 6-inch pipe: 20-inch offset
 - ii) 8 to 12-inch pipe: 15-inch offset
 - iii) 14 to 20-inch pipe: 8-inch offset
 - iv) 24 to 36-inch pipe: 6-inch offset
 - b. For laying restrained joint pipe in a vertical or horizontal curve, except for horizontal directional drills (HDD), each full length pipe may be deflected by the following offset distance:
 - 1) 6 to 12-inch pipe: 11-inch offset
 - 2) 16 to 20-inch pipe: 7-inch offset
 - 3) 24 to 30-inch pipe: 5-inch offset
 - 4) 36-inch pipe: 4-inch offset
 - 5) 42 to 48-inch pipe: 1 ¼ -inch offset
- E. PVC Pressure Pipe
- 1. Install PVC pipe in conformance with AWWA C605.
 - 2. Bell and Spigot Joints: Clean bell and spigot ends prior to jointing. Ends of field cut pipe shall be beveled with file. Gasket shall be clean and lightly lubricated. Joint shall be made as recommended by the manufacturer.
- F. Encasement Pipe
- 1. General
 - a. Verify the subsurface conditions at each boring site.
 - b. Stabilize and maintain bore pit bottom to provide proper equipment support and maintain pipe alignment. Dewater as necessary for site. Excavate bore pit in accordance with OSHA regulations. Provide adequate barricades, railings, and warning lights throughout the boring operation. Conduct operation in such a manner so as not to create a hazard to, nor impede the flow of traffic.
 - c. Install encasement pipe by dry boring and jacking.
 - d. Boring auger diameter shall not be greater than the outside diameter of the encasement pipe and shall not extend more than 6-inches ahead of the cutting edge of the encasement pipe. Fill voids that are formed during the operation with a 1:3 portland cement grout pumped at 50 psi to ensure that there will be no settlement of the roadway.
 - e. As the boring operation progresses, butt weld each new section of the encasement pipe to the section previously jacked into place. Maintain proper alignment. Confirm the grade of the encasement pipe as the Work progresses.
 - f. If an obstruction is encountered during the boring operation, efforts should be made to remove the obstruction. If obstruction cannot be removed, withdraw the encasement pipe and fill the void with 1:3 portland cement grout at 50 psi. If the encasement pipe cannot be withdrawn, seal ends before moving to another bore site. Town shall approve location of new bore site.
 - g. Provide seals at each end of encasement pipe as per Standard Detail.

2. Carrier Pipe
 - a. Install carrier pipe in the encasement pipe using manufactured pipe supports. Supports shall prevent movement of the carrier pipe within the encasement. Space supports as specified.
- G. Service Connections
 1. General
 - a. Make service connections in accordance with the standard detail.
 - b. Service connections to the main lines shall be perpendicular to the main line to the edge of the right-of-way or easement line.
 - c. Four-inch lines shall have a minimum slope of 1.0 % and have cleanouts every 75 feet at a minimum in addition to a cleanout at the right-of-way line or at the edge of the easement.
 - d. Six-inch lines shall have a minimum slope of 0.60 % and have cleanouts every 100 feet at a minimum in addition to a cleanout at the right-of-way line or at the edge of the easement.
 - e. 6-inch service lines shall tie directly into a manhole.
 - f. Service lines, which are connected into manholes, shall be installed less than 2.5 feet above the invert or shall be installed as a standard drop.
 - g. If a sidewalk is present or proposed, the cleanout shall be located behind the sidewalk.
- H. Anti-Seep Collars
 1. General
 - a. Anti-seep Collars: Provide anti-seep collars to prevent groundwater flow along pipe in wetlands. Collars shall extend past trench walls and bear against undisturbed soils. Dimension of collars shall be as indicated on the standard details. Do not place stone in area of anti-seep collars.
 - b. Concrete Collar: Provide Class B concrete with minimum cement content of 5 sacks per cubic yard (5.5 sacks for angular course aggregate); 6.8 gallons of water per sack water-cement ratio; 2-4 inch slump range; and 28-day strength of 2,500 psi.
- I. Pavement Patching
 1. General
 - a. Repair damaged pavement structure.
 - b. Cut existing pavement for utility installation in straight lines generally parallel to the utility. Properly dispose of removed pavement structure.
 - c. Extend pavement patch 1 foot beyond each side of trench on firm subgrade. Slope new surface to drain.
 - d. Asphalt Pavements: Replace asphalt pavement with a pavement structure no less than as shown on the Standard Details. For roadways under NC Division of Highways jurisdiction, pavement shall be replaced in accordance with their requirements.
 - e. Concrete Pavements: Replace concrete pavement with pavement structure equal to existing but no less than 6 inches. Concrete shall be minimum 3,000 psi. When existing concrete joint is within 5 feet of trench

remove existing concrete to joint. Provide expansion joint at edge of existing concrete. Surface treatment shall match existing.

- f. Curbs, Gutters, and Sidewalks: Replace curbs and gutters, and sidewalks removed or damaged with similar sections to match the existing. Remove to nearest existing joint.
- g. Approval of Other Authorities: Pavements under the jurisdiction of the NC Division of Highways shall be subject to the approval of a representative of that Division.

J. Grading and Clean-Up

1. General

- a. Provide for testing and clean-up as soon as practical, so these operations do not lag far behind the pipe installation. Perform preliminary clean-up and grading as soon as backfill is complete.
- b. Provide positive drainage of finished grade and drain away from structures. Finished grade shall be reasonably smooth, compacted, free from irregular surface changes and comparable to the adjacent existing ground surface.
- c. Seed disturbed areas.
- d. Upon completion of backfilling, remove and properly dispose of excess material and waste.

3.02 MANHOLES

A. General

- 1. Set base plumb and level. Align manhole invert with pipe invert.
- 2. Secure pipe connectors to pipe in accordance with manufacturer's recommendation.
- 3. Clean bells and spigots of foreign material that may prevent sealing. Unroll the butyl sealant rope directly against base of spigot. Do not stretch. Follow manufacturer's instructions when using O-ring seals.
- 4. Set precast components so that steps align.
- 5. Plug lift holes using a non-shrink grout. Cover with a butyl sealant sheet on the outside and seal on the inside with an application of an epoxy gel 1/8-inch thick extending 2 inches beyond the opening.
- 6. Set manhole frames to grade with grade rings. Seal joints between cone, adjusting rings, and manhole frame with butyl sealant rope and sheet.
- 7. Apply external seal to the outside of joint.
- 8. Finish the interior by filling fractures greater than 1/2-inch in length, width or depth with a sand cement mortar.
- 9. Clean the interior of the manhole of foreign matter
- 10. Ring and Cover shall be installed in accordance with Standard Details.

3.03 VALVES AND FITTINGS

A. General

1. Install buried valves on top of an 18-inch square, 3-inch thick, solid concrete pad (minimum dimensions). The concrete pad may be provided by a pre-cast manufacturer or cast-in-place in the field above grade. Concrete used for the pads shall be a minimum 3,000 psi mix. The pads may not be cast-in-place in the pipe trench. Connection to pipe shall be such that there shall be no stress at the joint caused by misalignment or inadequate support of pipe or valve.
2. Install fittings as recommended by the manufacturer. Fittings shall be blocked or otherwise restrained from movement.
3. Valve Boxes: Set valve boxes flush with finished grade. Box shall be supported so that no stress shall be transmitted to the valve. Operating nut shall be centered in box.
4. Install valves and other accessories in complete accordance with the manufacturer's recommendations.
5. Valve boxes shall be set straight with the operating nut centered and supported on (2) 4" concrete blocks, to prevent load transfer onto valve body or pipe line. Set top of box at finished grade. Provide a 24-inch x 24-inch wide by 6-inch thick concrete pad at top of valve boxes outside paved areas. Pre-cast pads may be allowed by the Town.
6. Air Valves
 - a. Main shall be drilled for the appropriate size connection.
 - b. Valve shall be installed on the main line with a service saddle.
 - c. Install air valve in a flat top manhole as per detail.

3.04 PUMP STATION

A. General

1. Install precast concrete wet well and valve vault in accordance with Paragraph 3.02 – MANHOLES of these specifications.
2. Install pumps and motors in accordance with manufacturer's installation instructions.
3. A spare pump and motor shall be provided with each pump station.
4. Electrical work shall be in accordance with all local, state and federal requirements. Contractor is responsible for obtaining all required permits and scheduling inspections. Coordinate electrical service to site with local power company.

3.05 ENGINE GENERATOR SYSTEM WITH AUTOMATIC TRANSFER SWITCH

A. Engine Generator

1. Install in accordance with manufacturer's instructions.
2. Provide fuel system piping as recommended by generator set manufacturer.
3. Provide wiring for fuel shutoff valve powered from generator set batteries and controlled by generator set control panel.
4. Provide interconnecting wiring between generator control panel and pump control panel.
5. Provide interconnecting wiring between generator control panel and telemetry system.
6. Provide interconnecting wiring between generator control panel and automatic transfer switch for automatic start.
7. Provide duplex receptacle, battery charger, alternator heater, and jacket heater branch circuits from an external source.

B. Automatic Transfer Switch

1. Install transfer switch in accordance with manufacturer's instructions.
2. Provide engraved plastic nameplates.
3. Provide generator start/stop signal wiring and conduit from transfer switch to generator control panel.
4. Provide interconnection wiring with duplex pump control circuit to allow only one pump to run while on generator power.
5. Provide 120 volt power source for heater.

PART 4 TESTING AND START-UP

4.01 PIPE AND ACCESSORIES

A. General

1. Clean and flush pipe system of foreign matter prior to testing.
2. Prior to pressure testing, the Town reserves the right to require the line to be pigged. If pigging of the line is required, Town staff shall be notified at least 48 hours prior to pigging of the line. Town staff must be present to witness and verify the insertion of the pig and additionally to be present to witness and verify the successful removal of the pig for each section pigged.
3. Notify the Town a minimum of 48 hours prior to testing.
4. Perform tests in the presence of the Town.
5. Length of line to be tested at one time shall be subject to approval of the Town.
6. Pipe sections shall not be accepted and placed into service until specified test limits have been met.
7. Repair defects in the pipe system. Make repairs to the same standard as specified for the pipe system.
8. Retest repaired sections until acceptance.
9. Repair visible leaks regardless of the test results.

10. Contractor shall provide all equipment required for testing.

B. Pressure Mains

1. The Town shall approve the source, quality, and method of disposal of water to be used in test procedures.
2. Obtain Town's permission 48 hours prior to filling or flushing of pipe system with water from Town's water system. Town shall operate valves connected to the existing water system. Keep pipe interior clean during construction to minimize the amount of water required for flushing. Where large quantities of water may be required for flushing, Town reserves the right to require that flushing be done at periods of low demand.
3. Pressure test in accordance with AWWA C600 for ductile iron pipe and AWWA C605 and M23 for PVC pipe and the following.
4. Make pressure tests between valves. Furnish suitable test plugs where line ends in "free flow."
5. Provide air vents at the high points in the line section to be tested for releasing of air during filling. Service corporation stops may be used for air vent when located at a high point. Leave corporation stops in place after testing and note locations on As-Constructed Drawings.
6. Allow concrete blocking to reach design strength prior to pressure testing.
7. Force main shall be completely filled with water, all air expelled from the pipe, and the discharge end of the pipeline shall be plugged and adequately blocked before hydrostatic test begins.
8. Upon completing a section of pipe between valves, test pipe by maintaining for a two hour period a hydrostatic pressure equal to 1.5 times the system working pressure or 150 psi, whichever is greater.
9. Test pressure shall not vary by more than +/- 5 psi for the duration of the test.
10. No length of line shall be accepted if the leakage is greater than that determined by the following formula based on the appropriate test pressure:
 - $L = \text{Allowable leakage per 1,000 feet of pipe in gallons per hour}$
 - $D = \text{Nominal diameter of the pipe in inches}$
 - 100 psi: $L = D \times 0.07$
 - 150 psi: $L = D \times 0.08$
 - 200 psi: $L = D \times 0.09$
 - 250 psi: $L = D \times 0.10$

C. Gravity Sewer Mains

1. Test gravity lines between manholes.
2. Light Testing: Town will check for displacement of pipe as follows:
 - a. A light will be flashed between the ends of the pipe section being tested.
 - b. If the illuminated interior shows misalignment, or other defects as designated by the Town, defects shall be repaired.
3. General

- a. Infiltration shall not exceed 100 gallons per inch of diameter, per mile of pipe, per 24 hours. Engineer may require flow measurement for verification of infiltration.
 - b. Verify that maximum infiltration rate shall not be surpassed by air testing as follows.
4. Low Pressure Air Test:
- a. Air testing of sewer mains shall conform to UNI-B-6 and the following requirements:
 - b. Perform initial air test when each section of main is complete including services to right of way. Test as construction proceeds.
 - c. Wet interior surfaces of porous pipe material prior to testing.
 - d. Safety
 - 1) Provide a superintendent who has experience in low pressure air testing of gravity sewer mains.
 - 2) Follow safety recommendations of air testing equipment manufacturer.
 - 3) Properly brace sewer plugs during testing. Test plugs prior to use in air testing.
 - 4) No one shall be allowed in manhole or trench when pipe is under pressure.
 - 5) Pressurizing equipment shall include a regulator and a pressure relief valve, which are set no higher than 9 psig. Monitor gauges continuously to assure that the pressure does not exceed 9 psig.
 - e. Equipment
 - 1) Sewer plugs shall be specifically designed for low pressure air testing.
 - 2) Use two separate air hoses.
 - i) One to connect the control panel to the sealed line for introducing the air.
 - ii) One from the sealed line to the control panel to provide constant monitoring of the air pressure in the line.
 - iii) If Pneumatic plugs are used a separate line shall be used to inflate the plugs.
 - 3) As a minimum the above ground air testing equipment shall include a shutoff valve, pressure regulating valve, pressure relief valve, input pressure gauge, and a continuous monitoring pressure gauge having a pressure range from 0 to at least 10 psig.
 - 4) Continuous monitoring pressure gauge shall be at least 4 inches in diameter with minimum divisions of 0.10 psi and an accuracy of +/- 0.04 psi.
 - 5) Monitoring gauges shall be subject to calibration as deemed necessary.
 - 6) Air used for testing shall pass through a single above ground control panel.

- f. Testing
 - 1) Groundwater Determination: Immediately prior to each air test, determine groundwater level by a method acceptable to the Engineer. Adjust pressure used in air test in accordance with groundwater level.
 - 2) Apply air slowly to the test section until the pressure reached is 4.0 psi plus an adjustment of 0.433 psi for each foot of ground water above the crown of the pipe. Internal air pressure, including adjustment for ground water, should never exceed 9.0 psi.
 - 3) When the above required pressure is reached, throttle air supply to maintain internal pressure for at least two minutes to permit stabilization.
 - 4) When pressure has stabilized at required pressure, shut off air supply.
 - 5) While observing the continuous monitoring pressure gauge, decrease pressure approximately 0.5 psi from required pressure.
 - 6) At this reading timing shall commence with a stop watch and allowed to run until pressure has dropped 1.0 psi or allowable time has lapsed. Line shall be "Acceptable" if the pressure drop does not exceed 1 psig in the time prescribed for the test in Standard Detail, S-1.21, Low Pressure Air Testing for Gravity Sewer Mains.
- 5. Deflection Test for SDR 21 and PVC Pipe
 - a. Measure for deflection of pipe no sooner than thirty days after installation and backfill.
 - b. Deflection shall not exceed 5 percent of pipe diameter. Maximum allowable long term deflection shall be 5 percent.
 - c. Measure deflection with an approved "GO-NO-GO GAUGE" method or by an approved recording deflectometer. Verify gauge on site prior to testing.
- 6. When gravity sewer mains do not meet the required minimum separation from wells, water mains or streams, hydrostatic testing shall be performed as follows:
 - a. The source, quality, and method of disposal of water to be used in test procedures shall be approved by the Town.
 - b. Obtain Town's permission 48 hours prior to filling or flushing of pipe system with water from Town's water system. Town shall operate valves connected to the existing water system.
 - c. Air test line, as described above, prior to hydrostatic testing.
 - d. Provide taps for filling and pressurizing the line. Service corporation stops may be used. Include cost of taps in price of testing. Leave corporation stops in place after testing and note locations on As-Constructed Drawings.
 - e. Suitable means for thrust restraint shall be installed for testing.
 - f. Test for each manhole reach.
 - g. Test pipe by maintaining for a two-hour period a hydrostatic pressure of 150 psig.

- h. Test pressure shall not vary by more than +/- 5 psi for the duration of the test.
- i. Pressure test in accordance with AWWA C600 for ductile iron pipe and as described above.

4.02 MANHOLES

A. General

- 1. Vacuum test each manhole in accordance with ASTM C1244 and the following:
 - a. No personnel shall be allowed in manhole during testing.
 - b. Test manhole after assembly and prior to backfilling.
 - c. Plug pipes with suitably sized and rated pneumatic or mechanical pipeline plugs. Brace plugs to prevent displacement.
 - d. Position vacuum test head assembly to seal against interior surface of the top of cone section in accordance with manufacturer's recommendation.
 - e. Draw vacuum of 10 inches of mercury on manhole. Shut off the vacuum pump and close valve on vacuum line.
 - f. Measure time for vacuum to drop to 9 inches of mercury. Manhole shall pass if time meets or exceeds the following:

Manhole I.D. (inches)	48	60	72	84	96	120
Seconds	60	75	90	105	120	150

- g. If manhole fails test, remove head assembly, coat interior with a soap and water solution, and repeat vacuum test for approximately 30 seconds. Leaking areas will have soapy bubbles. Make necessary repairs to the satisfaction of Town and repeat test until manhole passes.

4.03 PUMP STATION

A. Wet Well and Valve Vault

- 1. Test wet well for water-tightness. Perform water-tightness test in the presence of the Town.
- 2. Water-tightness test shall be in accordance with ACI 350.1R/AWWA 400 "Testing Reinforced Concrete Structures for Water-Tightness." Plug influent line and fill wet well with water to 6-inches below the force main pipe. Allow water to sit for 24 hours to allow for absorption by the concrete. There shall be no loss of water over a 24 hour period. If the water level has dropped the test may be run again at the Contractor's option. If the test fails a second time, the interior of the wet well shall be coated with water proofing compound and the wet well retested.
- 3. Vacuum test may be used upon approval of the Town. Test shall meet the requirement for manhole testing as indicated in Paragraph 4.02 – MANHOLES of these requirements.
- 4. Submit record of test signed by the Contractor.

B. Pump Operations

- 1. A Certified Performance Test shall be performed on each pump at the factory before delivery to the site.

2. Provide the services of manufacturer's representative to check the pump station installation, supervise initial start up, and instruct the Town's personnel in proper operation and maintenance of the pumps and appurtenances. A minimum of two separate trips to the site will be required, each consisting of a minimum of one 8 hour working day. Regardless of the time spent at the site, services will not be considered complete until the pump station operates as intended for a minimum of one (1) week of operation.
3. Operate pump station under actual field service to demonstrate that all equipment performs to the specified criteria, flow capacity and head conditions. During the field test, make adjustments as necessary for proper operation. Adjust impeller size as necessary to meet field conditions.
4. Manufacturer's recommended start up tests shall be performed according to the installation schedule. Start up tests shall include the following as a minimum:
 - a. Data for each pump under operating conditions:
 - 1) Amperage reading.
 - 2) Pressure head reading.
 - 3) Drawdown flow test.
 - b. Pull out each pump and reinstall using guide rails and hoist.
 - c. Test alarm condition for high flow.
 - d. Test auxiliary contacts.
 - e. Test float control system.
5. Submit copy of tests and checks performed in the field, complete with recordings, where applicable, to the Town.

4.04 ENGINE GENERATOR SYSTEM WITH AUTOMATIC TRANSFER SWITCH

A. Engine Generator System

1. Provide the services of manufacturer's representative to check the equipment installation, supervise initial start-up, and instruct Town's personnel in proper operation and maintenance of the equipment. A minimum of one trip to the site will be required, consisting of a minimum of one 8-hour working day. Regardless of the time spent at the site, services will not be considered complete until the system operates as intended for a minimum of one (1) month of operation.
2. Provide a four hour full load test utilizing portable test bank. Simulate power failure including operation of transfer switch, automatic starting cycle, automatic shutdown, and return to normal. The load bank test shall be performed at the job site and shall include one hour at 50% load, one hour at 75% load, one hour at 100% load, and one hour at 50% load. Any defects that become evident during the test shall be corrected. Safety shutdown features shall be tested by simulating the primary device contact closure.
3. Record in 20 minute intervals during four hour test:
 - a. Kilowatts.
 - b. Amperes.
 - c. Voltage.
 - d. Coolant temperature.

- e. Ambient temperature.
 - f. Frequency.
 - g. Oil pressure.
4. Test alarm and shutdown circuits by simulating conditions.
 5. Describe loads connected to standby system and restrictions for future load additions.
 6. Adjust generator output voltage and engine speed.
 7. Clean engine and generator surfaces. Replace oil and fuel filters at time of final acceptance by the Town.
 8. Provide required fuel for testing and start up services.
 9. Provide complete charges of oil and antifreeze at time of final acceptance by the Town.
 10. Fuel tank shall be filled at time of final acceptance by the Town
- B. Automatic Transfer Switch
1. Manufacturer's representative shall prepare and start-up system in accordance with manufacturer's recommendation.
 2. Fully demonstrate, in the presence of the Town's representatives, the operation of the switch in normal and emergency modes.

4.05 CLOSED CIRCUIT TVING OF GRAVITY LINES

A. General

1. Following installation of gravity lines, Contractor shall visually inspect each line by means of close-circuit television (CCTV). Video shall be recorded on a DVD.
2. Television camera used for the inspection shall be one specifically designed and constructed for such inspection. Lighting for the camera shall be suitable to allow a clear picture for the entire periphery of the pipe. Camera shall be operative in 100 percent humidity conditions. Components of the video system shall be capable of producing a minimum 310 line resolution. Lighting system shall minimize reflective glare. Camera shall move through at a constant rate with a maximum speed of 30 feet per minute.
3. Deliver DVD to the Town prior to final acceptance.

4.06 "AS-CONSTRUCTED" DRAWINGS

A. General

1. Maintain on-site a full set of project drawings for purpose of recording as-constructed conditions.
2. Information should be legibly recorded as construction progresses.
3. Clearly and completely identify any field changes from the original drawings.
4. The depth of all force mains shall be recorded at all roadways, waterway crossings, utilities crossings and all other areas as needed to accurately

define the vertical location of the force main. A minimum of one depth shall be recorded on each 100 feet of pipe installed. Depth shall be referenced to finished surface grades.

5. Show horizontal and vertical location of any existing underground utilities encountered during construction.
6. Submit document to the Town prior to final acceptance.
7. All new features shall be surveyed utilizing survey grade GPS equipment and digital file with all surveyed information shall be provided to the Town.
8. A digital CADD file shall be provided to the Town that contains all the features constructed with the updated as-built information along with survey data.
9. The Town shall have the right to employ an independent survey firm to verify the "As-Constructed" Drawings submitted by the Contractor at the end of the project. If components or the drawings are determined to be incorrect, the Contractor shall have all items corrected to obtain final approval by the Town. The Contractor will also be responsible for reimbursing the Town for all associated costs related to verification, review, and other costs arising from any corrections having to be made in order to provide correct plans and files to the Town.

❖ END OF SECTION ❖

NOTES:

- 1) PRECAST MANHOLE SHALL CONFORM TO ASTM C478 WITH AASHTO M198 BUTYL SEALS BETWEEN JOINTS AND 6" ADHESIVE TAPE ON THE OUTSIDE OF JOINTS.
- 2) MANHOLE RING SHALL BE FLUSH WITH PAVED SURFACES AND LAWNS. SET 2 TO 3 FEET ABOVE GRADE IN UNIMPROVED AREAS.
- 3) MANHOLE RIMS SHALL BE SET 2 FEET MIN. ABOVE 100 YEAR FLOOD ELEVATION, OR USE WATERTIGHT LIDS.
- 4) USE 5' DIA. MANHOLE WHERE DEPTH IS GREATER THAN 15 FEET.
- 5) HOLES FOR CONNECTION OF PIPE TO MANHOLE SHALL BE PRECAST OR CORED. DIAMETER OF HOLE SHALL NOT EXCEED OUTSIDE DIAMETER OR PIPE BY MORE THAN 3 INCHES.
- 6) CONNECTION OF PIPE TO MANHOLE SHALL BE MADE WATERTIGHT USING RESILIENT CONNECTORS CONFORMING TO ASTM C 923 OR NEOPRENE BOOTS EMBEDDED IN PRECAST BASE WITH STAINLESS STEEL COMPRESSED BANDS. AREA AROUND CONNECTION SHALL BE GROUTED W/ NON-SHRINK GROUT ONCE PIPE IS INSTALLED.
- 7) IF PIPES ARE GREATER THAN 12" DIA. AND/OR THE ANGLE BETWEEN 2 OR MORE SEWER PIPES ARE LESS THAN 60°, A 5' DIA. (MIN.) MANHOLE SHALL BE USED.

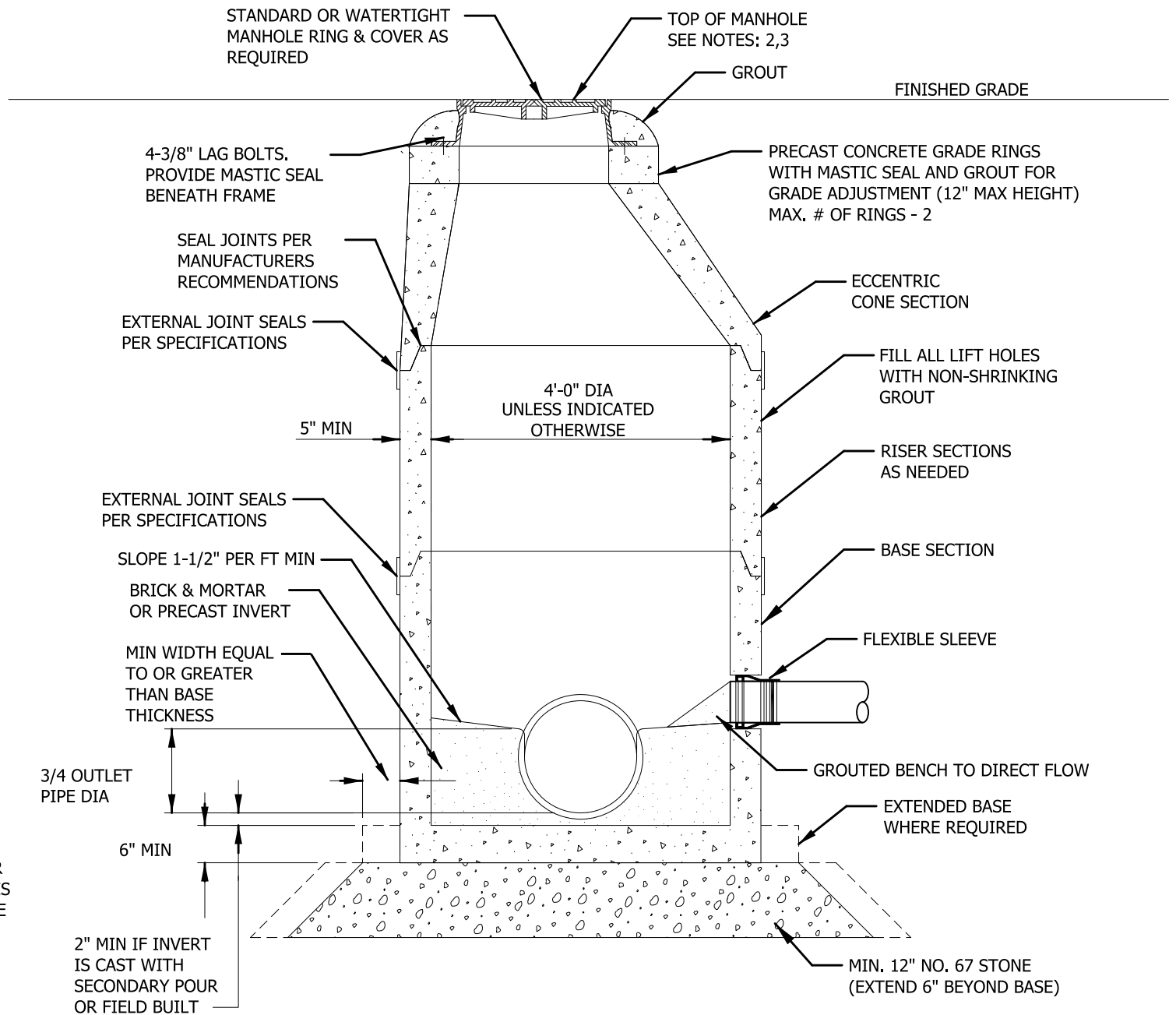

STANDARD PRECAST CONCRETE MANHOLE



DATE:	REVISIONS

STANDARD DETAIL

DATE: 02/17/20
SHEET 1 OF 1
STD. No. S-1.01

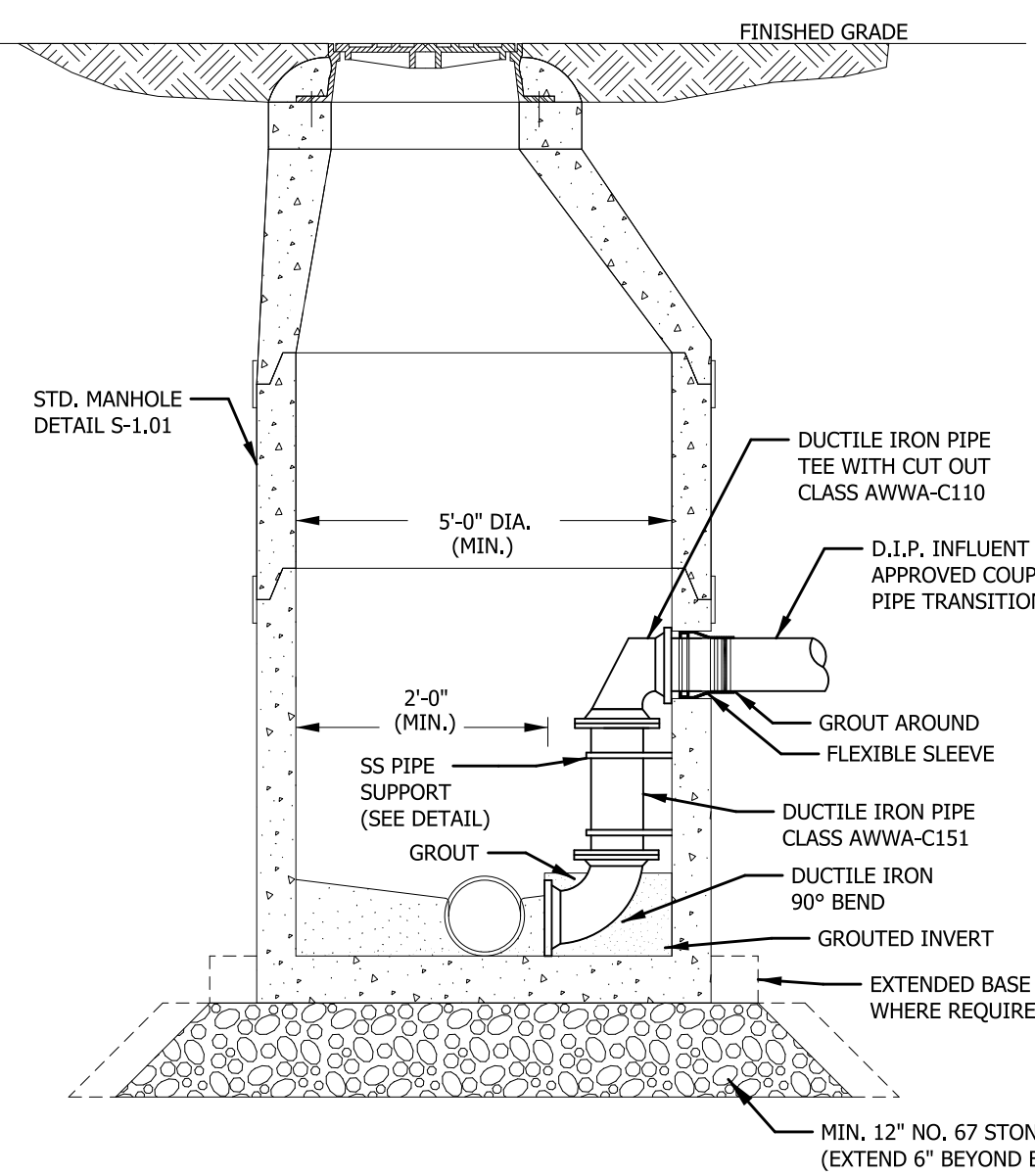

3/4" STAINLESS STEEL ANCHOR BOLT, MIN. 2" ENBEDMENT

2" X 1/4" STAINLESS STEEL STRAP AND DOUBLE NUTS. TIGHTEN SNUG AROUND PIPE. DO NOT COMPRESS PIPE OR TEFLON SHEETING.

50 MIL. TEFLON SHEET. WRAP AROUND PIPE (3" WIDE)

STAINLESS STEEL PIPE SUPPORT STRAP

NOTES:

- 1) PIPE SIZE FOR DROP TO EQUAL INFLOW SEWER PIPE SIZE.
- 2) MECH. JOINT FITTINGS, TO BE USED.
- 3) SAW-CUT OR DRILL ALL HOLES FOR PIPE AND BOLTS.
- 4) DROP-MANHOLE MANDATORY WHEN DIFFERENTIAL BETWEEN INVERTS IS GREATER THAN 30".
- 5) INSTALL STAINLESS STEEL STRAPS WITHIN 12" OF EACH PIPE JOINT AND AT 18 INCH MAX SPACING (MIN 2 REQD).

STANDARD I NSIDE DROP MANHOLE

DATE:	REVISIONS

STANDARD DETAIL

DATE: 02/17/20
SHEET 1 OF 1
STD. No. S-1.02



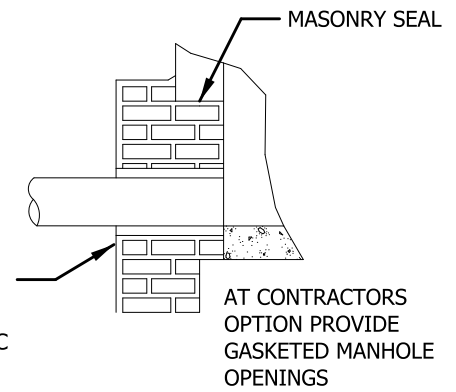
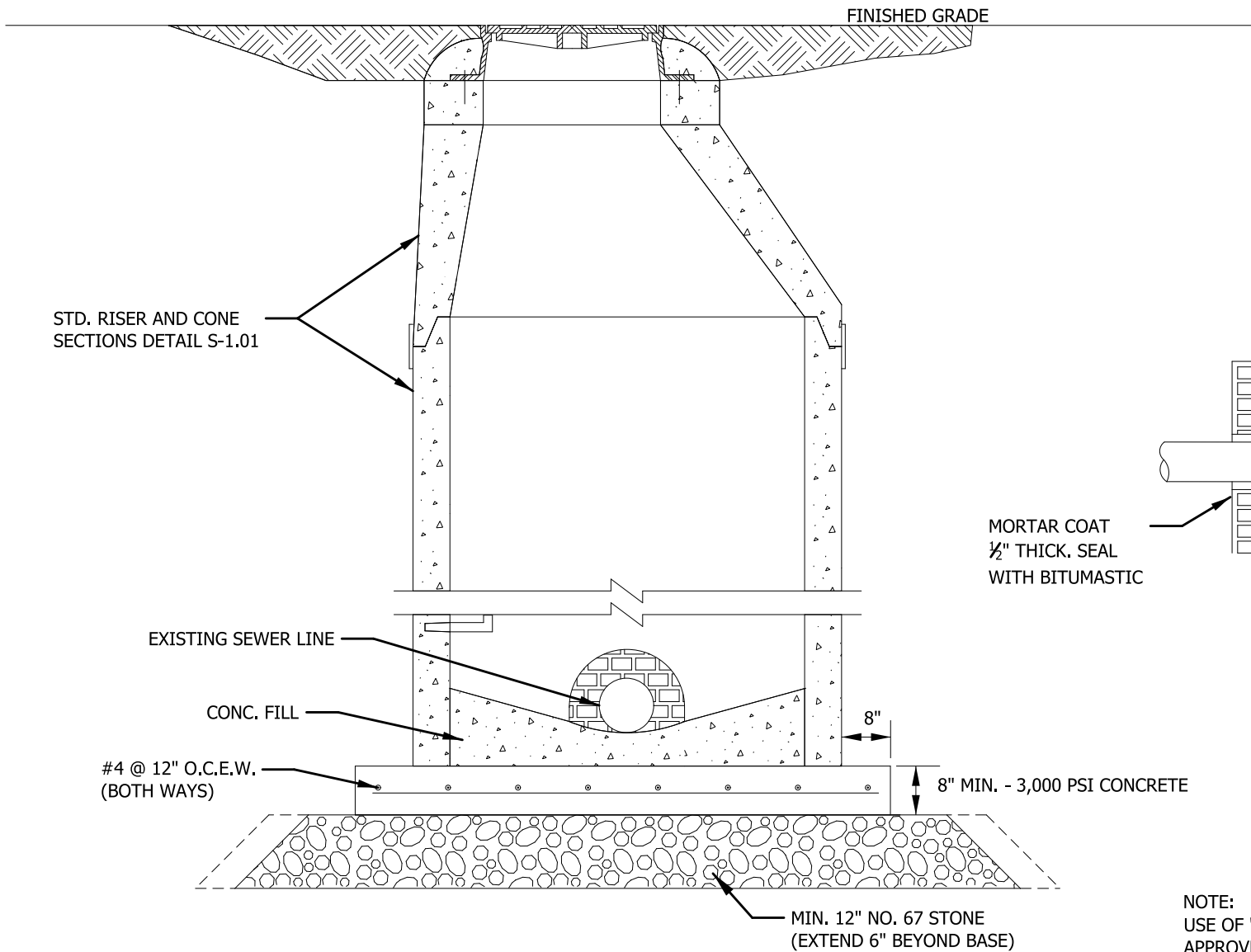

NOTE:
 USE OF "DOGHOUSE" TYPE MANHOLE MUST BE APPROVED IN WRITING BY THE TOWN PRIOR TO USE
 PREFERRED OPTION IS TO INSTALL NEW MANHOLE

STANDARD ' DOGHOUSE ' TYPE MANHOLE

DATE:	REVISIONS

STANDARD DETAIL

DATE: 02/17/20
SHEET 1 OF 1
STD. No. S-1.03



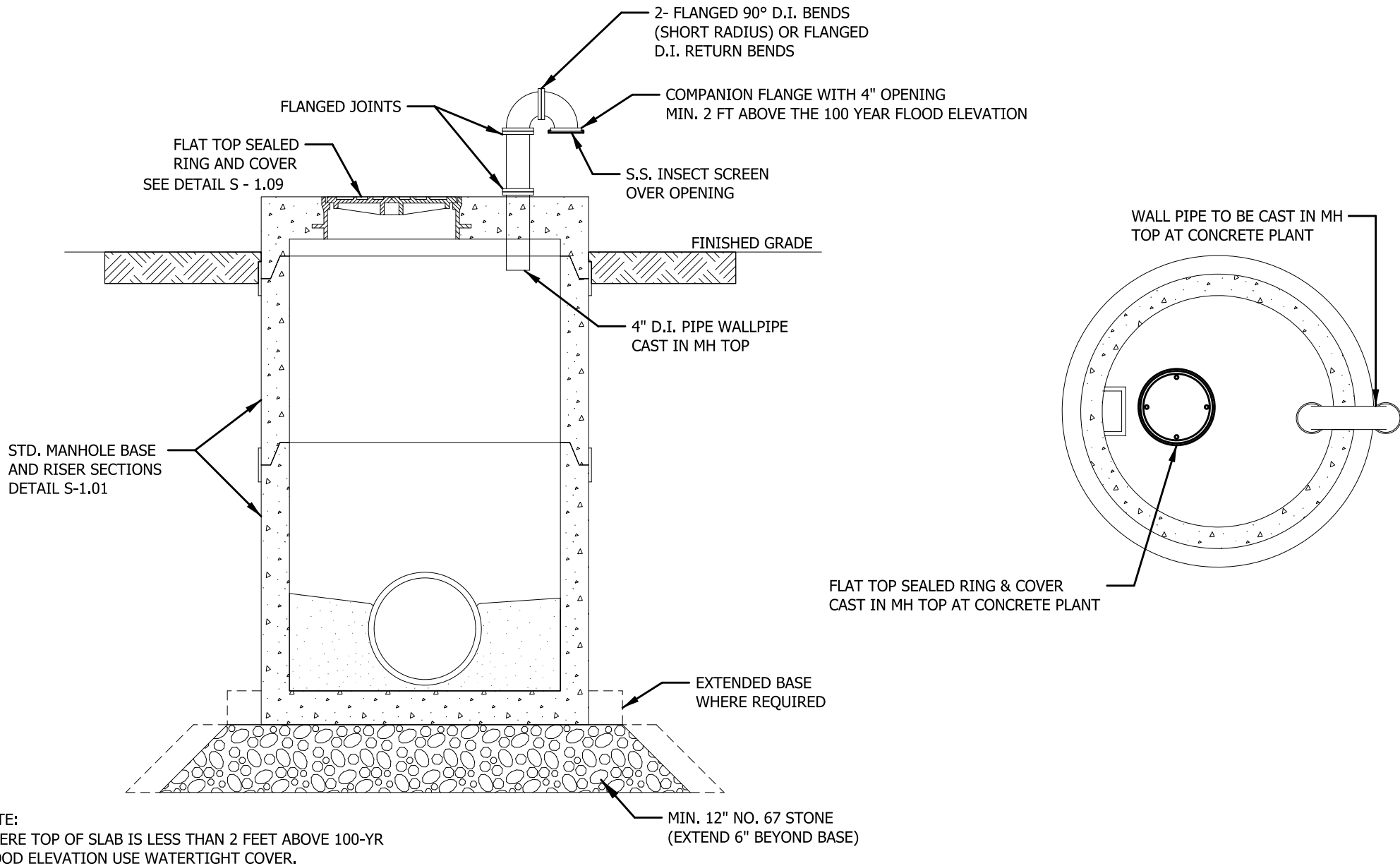

STANDARD FLAT TOP SEALED AND VENTED MANHOLE



DATE:	REVISIONS

STANDARD DETAIL

DATE: 02/17/20
SHEET 1 OF 1
STD. No. S-1.04

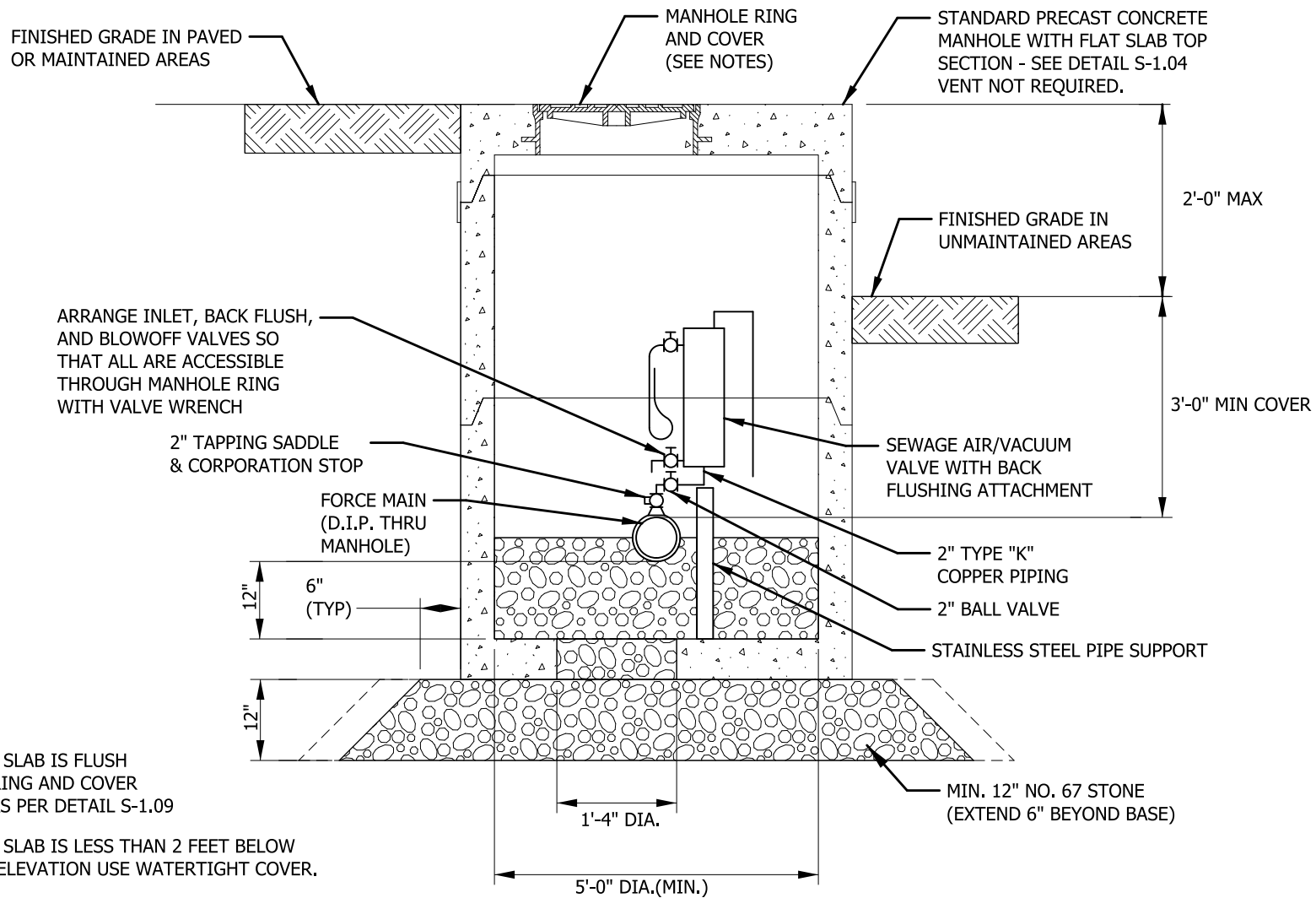

STANDARD SEWAGE AIR RELEASE MANHOLE



DATE:	REVISIONS

STANDARD DETAIL

DATE: 02/17/20
SHEET 1 OF 1
STD. No. S-1.05

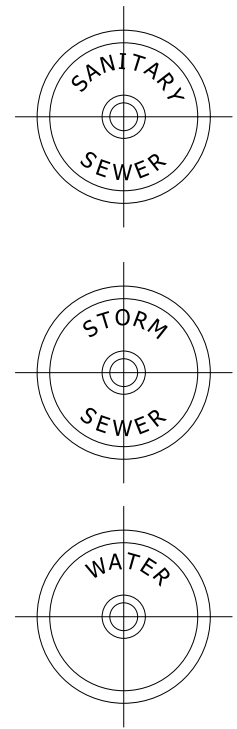
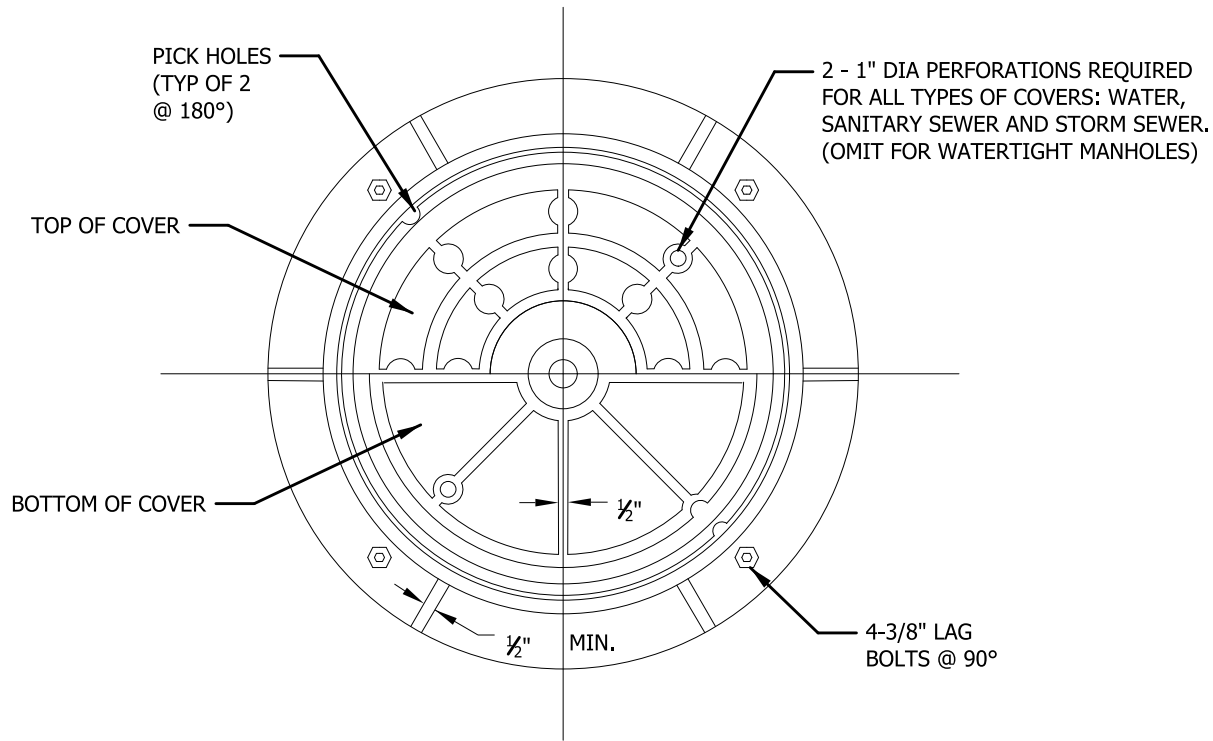

COVER LETTERING DETAIL

NOTES:

- 1) RING AND COVER SHALL HAVE TOTAL COMBINED WEIGHT OF 310 LB MIN. AND BE SUITABLE FOR H-20 LOADING.
- 2) ALL BOLTS ARE TO BE TYPE 316 STAINLESS STEEL.
- 3) USE COVER LETTERING AS APPROPRIATE FOR APPLICATION.

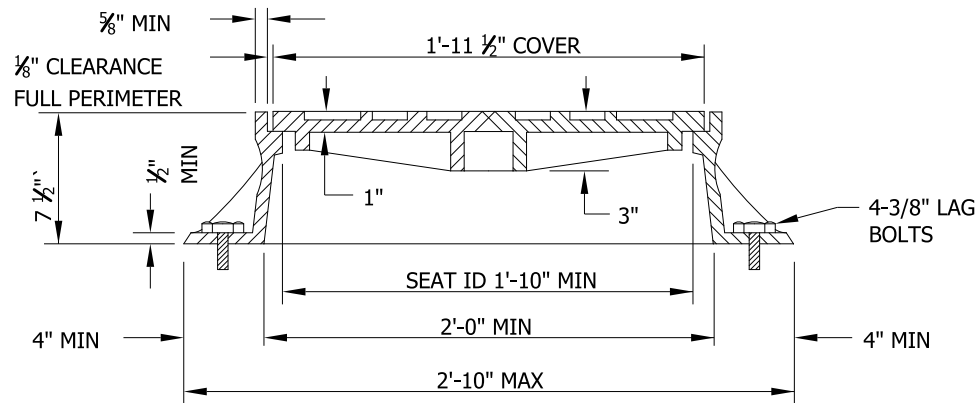

STANDARD MANHOLE RING AND COVER



DATE:	REVISIONS

STANDARD DETAIL

DATE: 02/17/20
 SHEET 1 OF 1
 STD. No. S-1.06

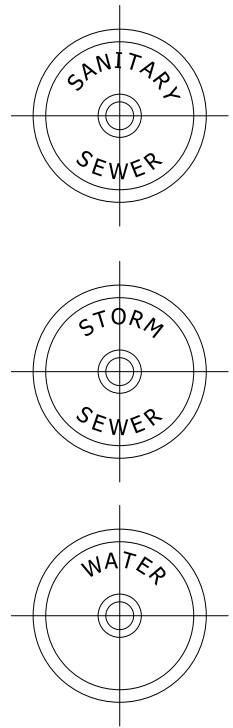
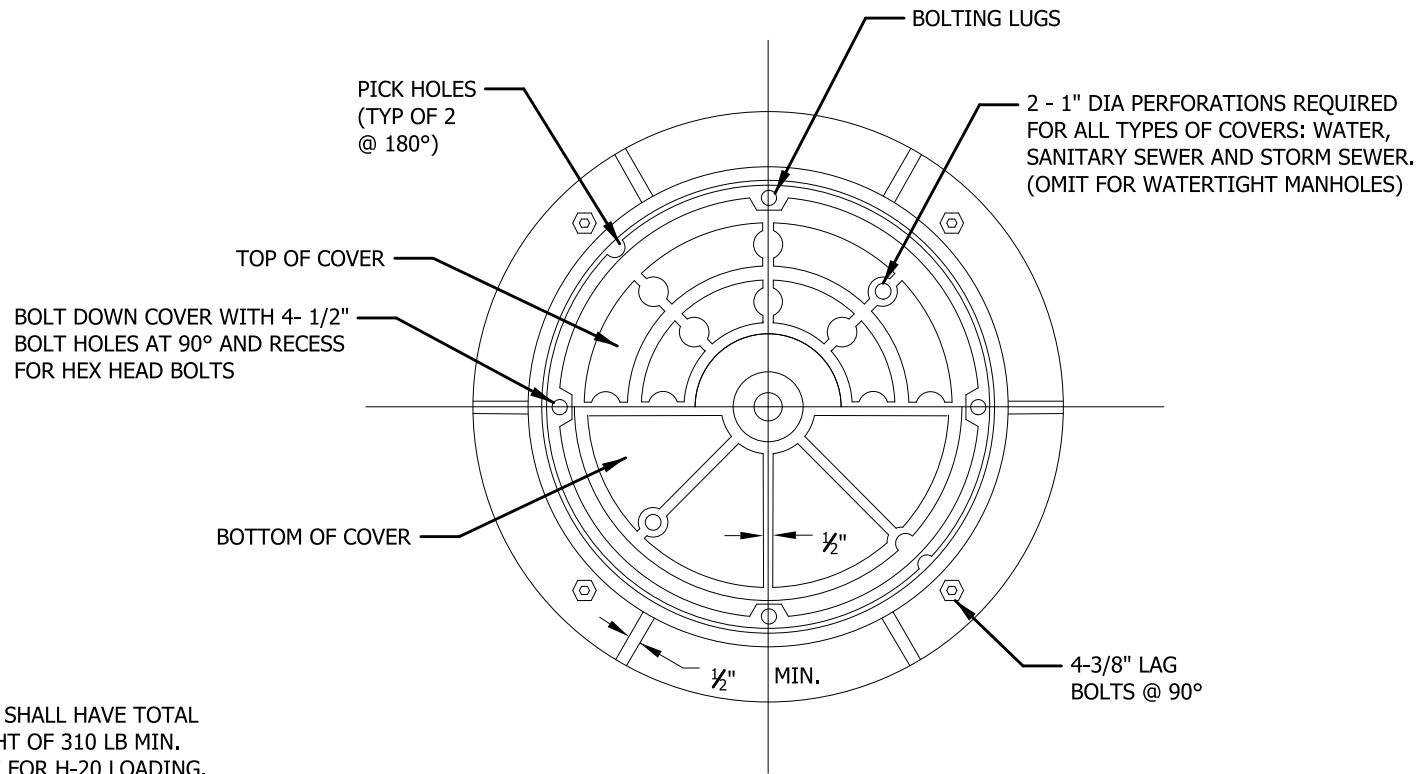

COVER LETTERING DETAIL

- NOTES:**
- 1) RING AND COVER SHALL HAVE TOTAL COMBINED WEIGHT OF 310 LB MIN. AND BE SUITABLE FOR H-20 LOADING.
 - 2) ALL BOLTS ARE TO BE TYPE 316 STAINLESS STEEL.
 - 3) USE COVER LETTERING AS APPROPRIATE FOR APPLICATION.
 - 4) PRIOR TOWN APPROVAL MUST BE OBTAINED IN ORDER TO USE.

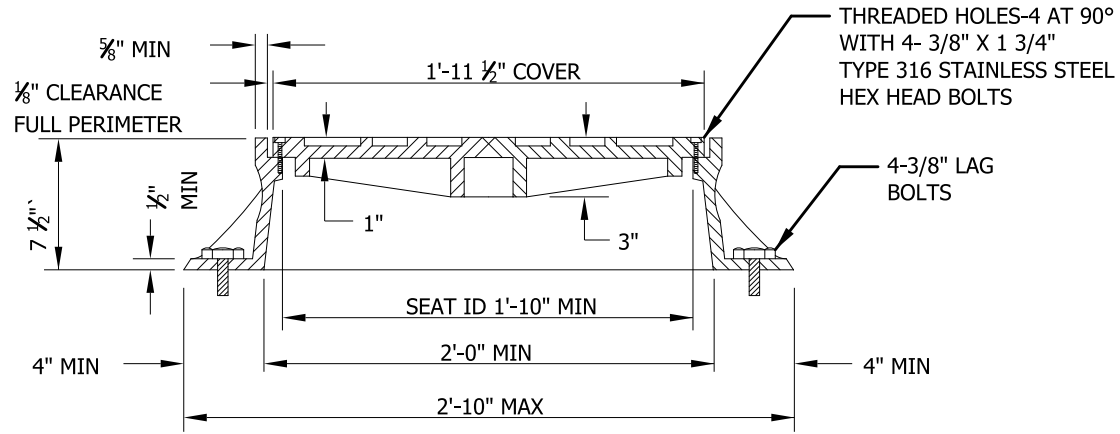

STANDARD MANHOLE RING WITH BOLT DOWN COVER

DATE:	REVISIONS

STANDARD DETAIL

DATE: 02/17/20
SHEET 1 OF 1
STD. No. S-1.07



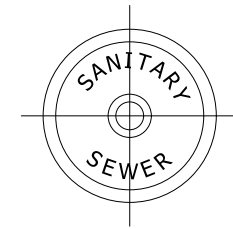
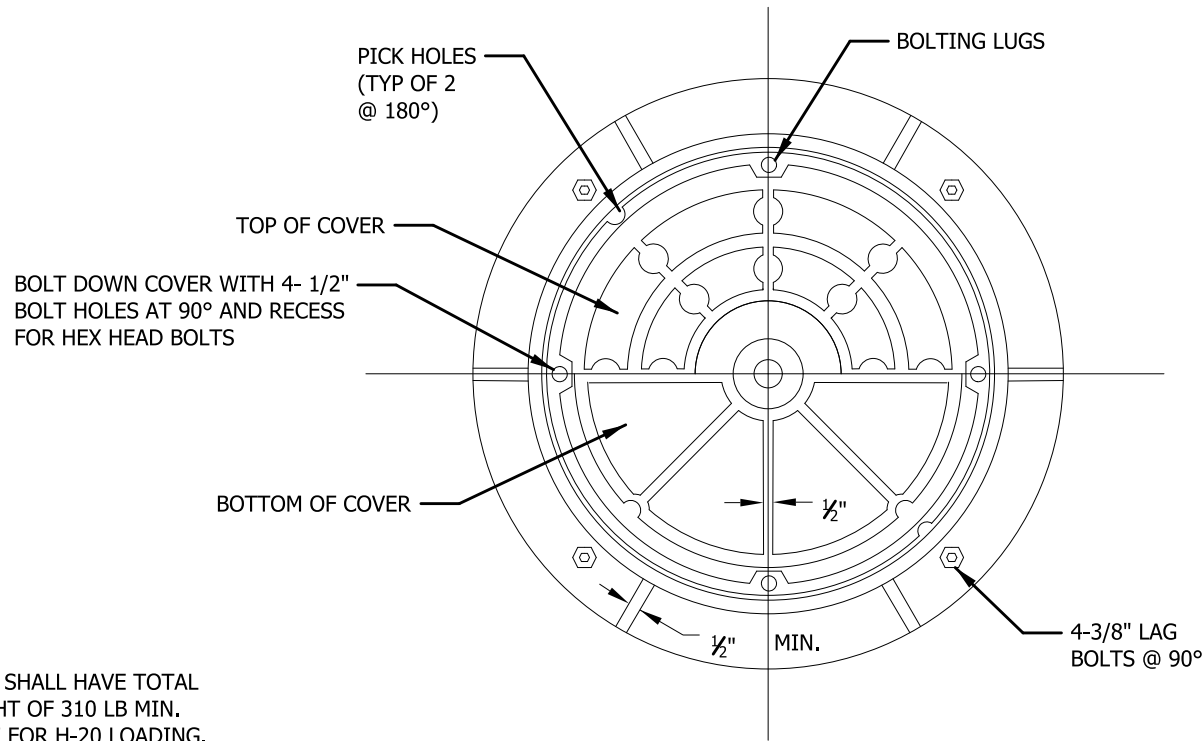

COVER LETTERING DETAIL

- NOTES:
- 1) RING AND COVER SHALL HAVE TOTAL COMBINED WEIGHT OF 310 LB MIN. AND BE SUITABLE FOR H-20 LOADING.
 - 2) ALL BOLTS ARE TO BE TYPE 316 STAINLESS STEEL.
 - 3) USE COVER LETTERING AS APPROPRIATE FOR APPLICATION.

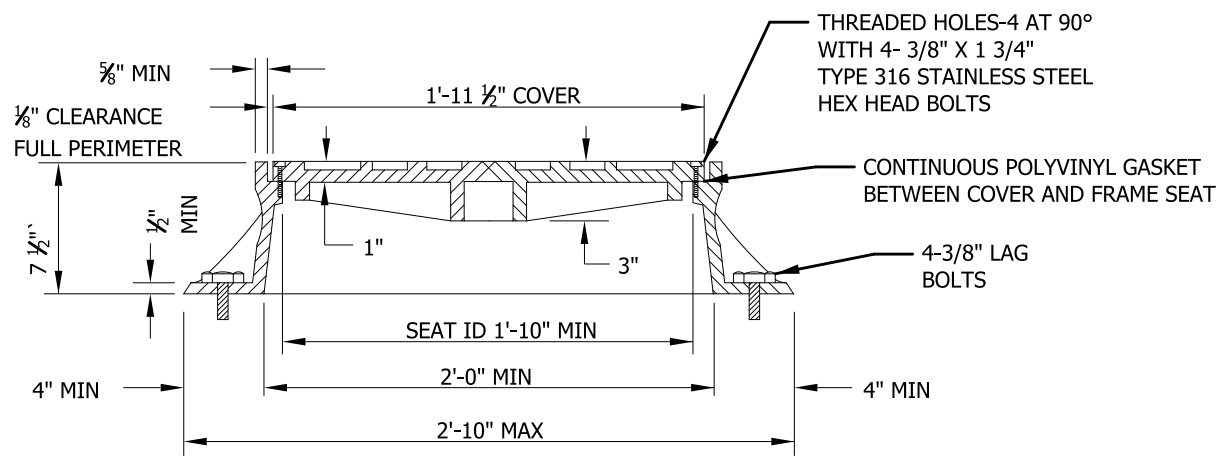

STANDARD MANHOLE RING AND COVER FOR WATERTIGHT MANHOLES



DATE:	REVISIONS

STANDARD DETAIL

DATE: 02/17/20
SHEET 1 OF 1
STD. No. S-1.08

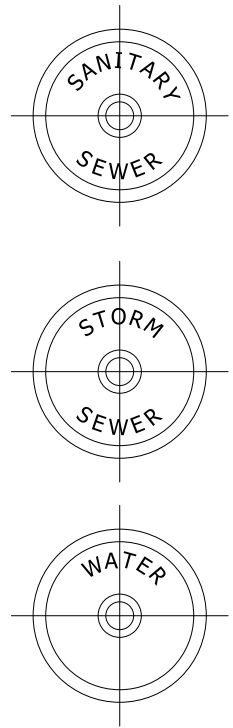
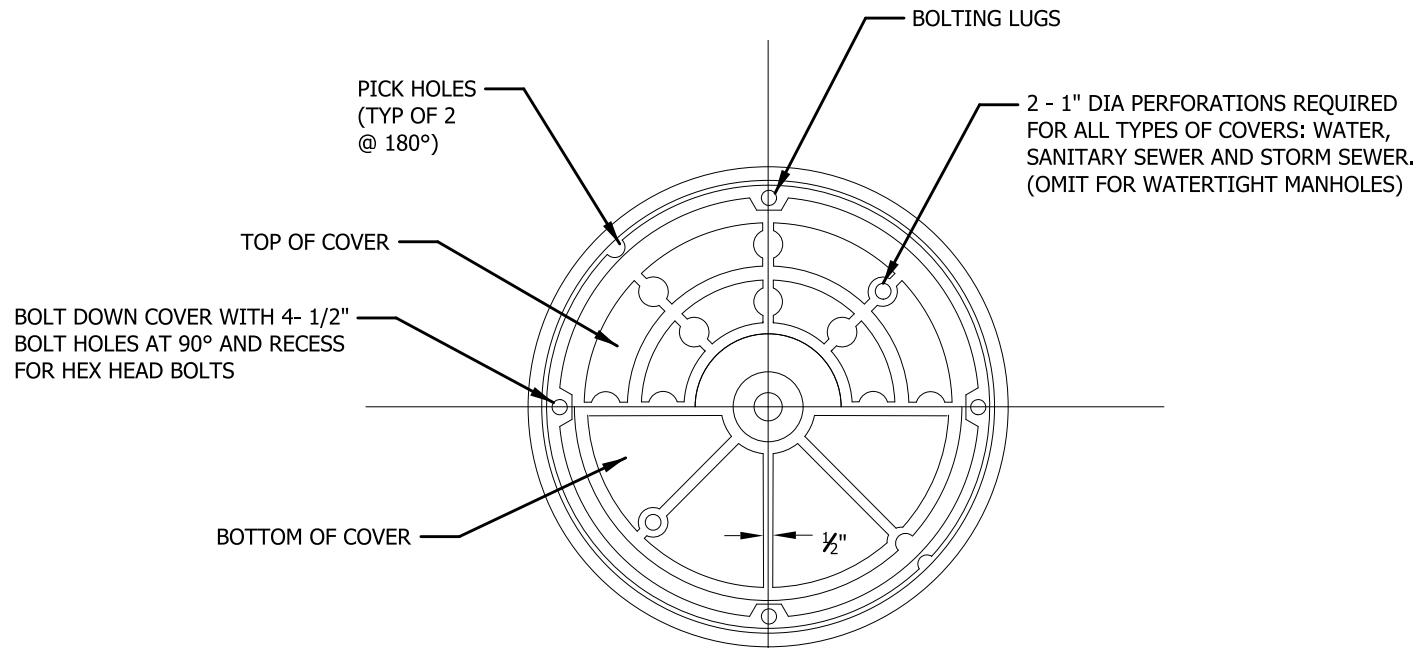

COVER LETTERING DETAIL

- NOTES:
- 1) ALL BOLTS ARE TO BE TYPE 316 STAINLESS STEEL.
 - 2) USE COVER LETTERING AS APPROPRIATE FOR APPLICATION.
 - 3) RING AND COVER WILL HAVE MACHINED SEAT AND WILL CONFORM TO ASTM A48, CLASS 35B

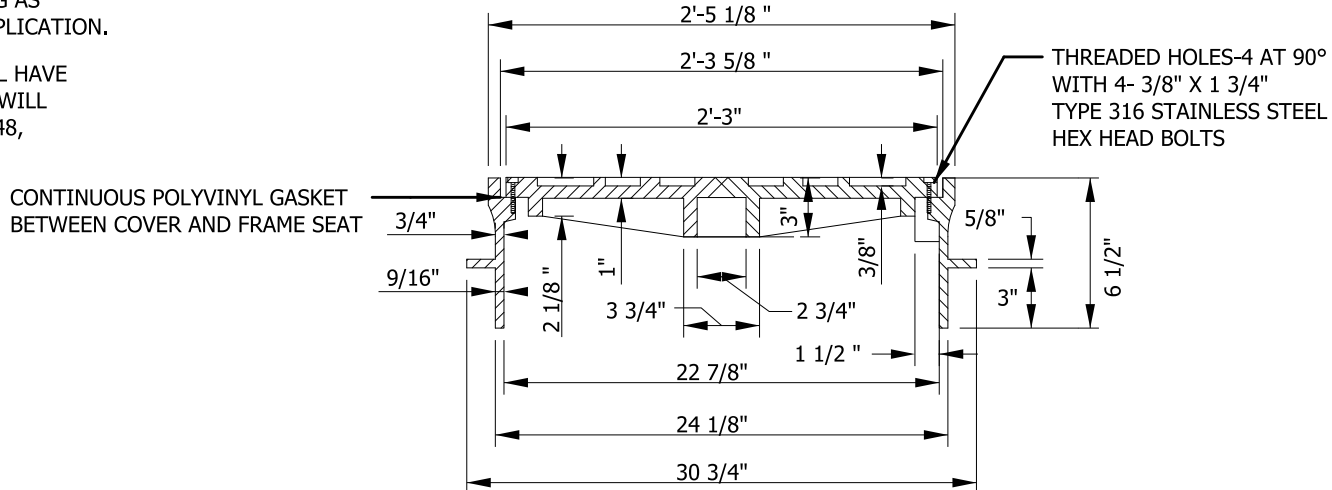

FLAT TOP SEALED RING & COVER

DATE:	REVISIONS

STANDARD DETAIL

DATE: 02/17/20
SHEET 1 OF 1
STD. No. S-1.09



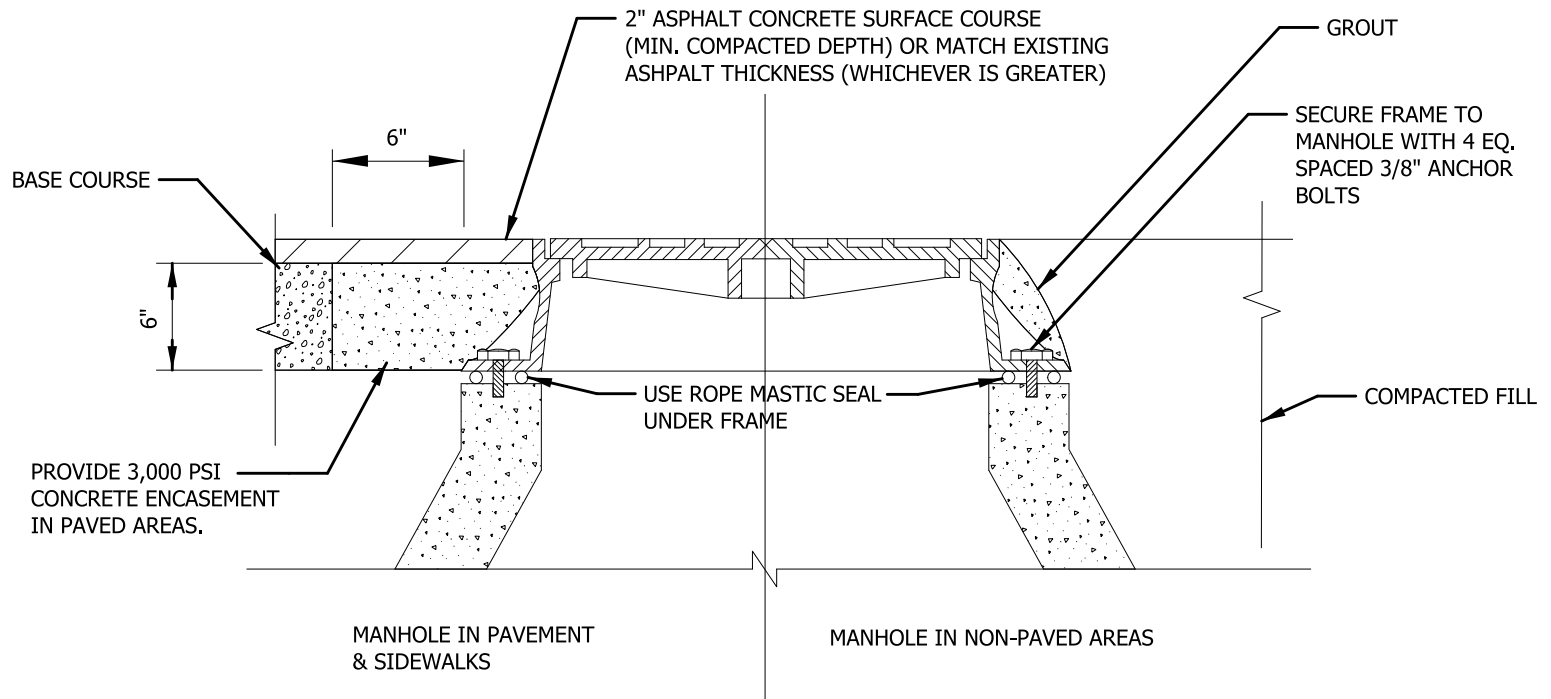

PROVIDE 3,000 PSI
CONCRETE ENCASEMENT
IN PAVED AREAS.

MANHOLE RING AND COVER ANCHORING



DATE:	REVISIONS

STANDARD DETAIL

DATE: 02/17/20
SHEET 1 OF 1
STD. No. S-1.10

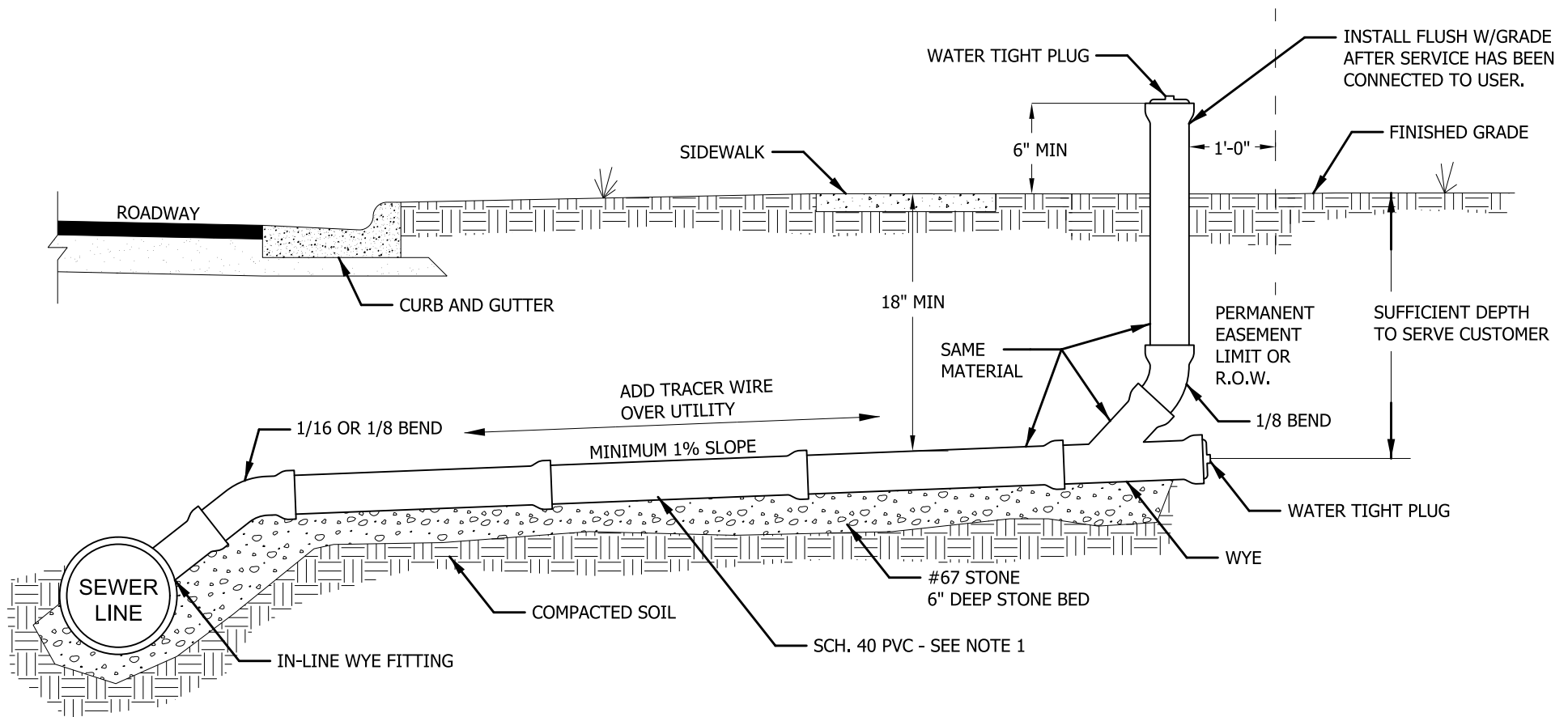

NOTES:

- 1) USE D.I.P. FOR LATERAL IF DEPTH IS LESS THAN 3 FT. OR GREATER THAN 12 FT.
- 2) NO TAPPING SADDLES ALLOWED FOR NEW MAIN CONSTRUCTION. IF USED ON AN EXISTING LINE, SADDLE SHALL BE ROMAC INDUSTRIES STYLE CB OR APPROVED EQUAL.
- 3) NO TAPPING OF CLEAN OUT RISER. CONNECTION MUST BE MADE TO PLUGGED END.
- 4) SEWER SERVICE PIPING AND FITTINGS TO BE 4" UNLESS OTHERWISE SPECIFIED.

DEPTH < 20 FEET:

- UNDERCUT TRENCH BOTTOM 6 INCHES MINIMUM BELOW PIPE
- FILL PIPE TO SPRING LINE WITH NO. 67 STONE

DEPTH > 20 FEET:

- UNDERCUT TRENCH BOTTOM 6 INCHES MINIMUM BELOW PIPE
- FILL TO 6 INCHES ABOVE PIPE WITH NO. 67 STONE

STANDARD SANITARY SEWER SERVICE



DATE:	REVISIONS

STANDARD DETAIL

DATE: 02/17/20
SHEET 1 OF 1
STD. No. S-1.11

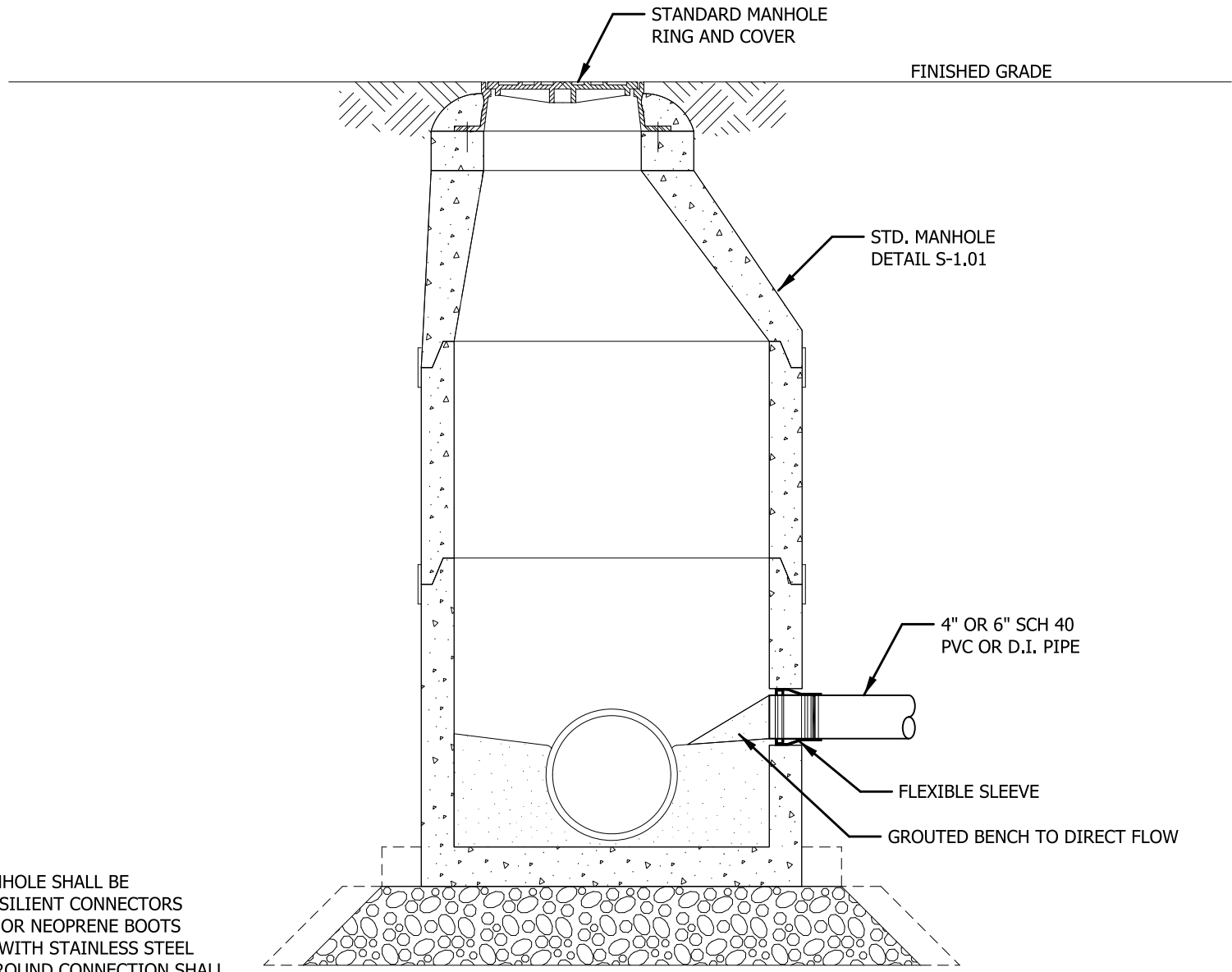

NOTE:
 CONNECTION OF PIPE TO MANHOLE SHALL BE MADE WATERTIGHT USING RESILIENT CONNECTORS CONFORMING TO ASTM C 923 OR NEOPRENE BOOTS EMBEDDED IN PRECAST BASE WITH STAINLESS STEEL COMPRESSED BANDS. AREA AROUND CONNECTION SHALL BE GROUTED W/ NON-SHRINK GROUT ONCE PIPE IS INSTALLED.

SEWER LATERAL CONNECTION TO MANHOLE



DATE:	REVISIONS

STANDARD DETAIL

DATE: 02/17/20
SHEET 1 OF 1
STD. No. S-1.12

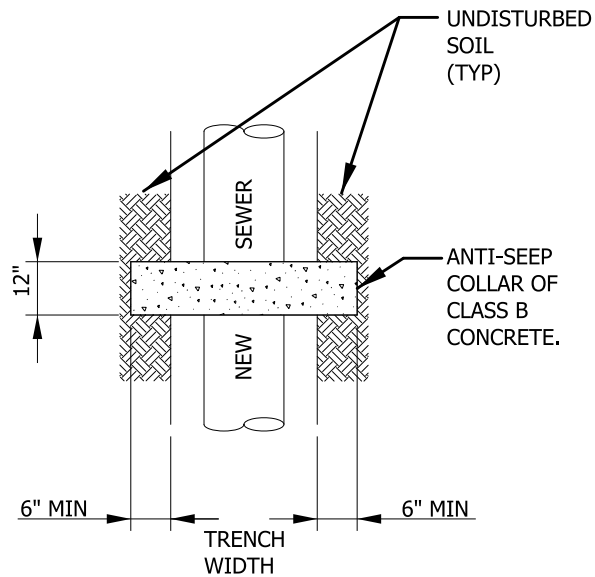

PLAN

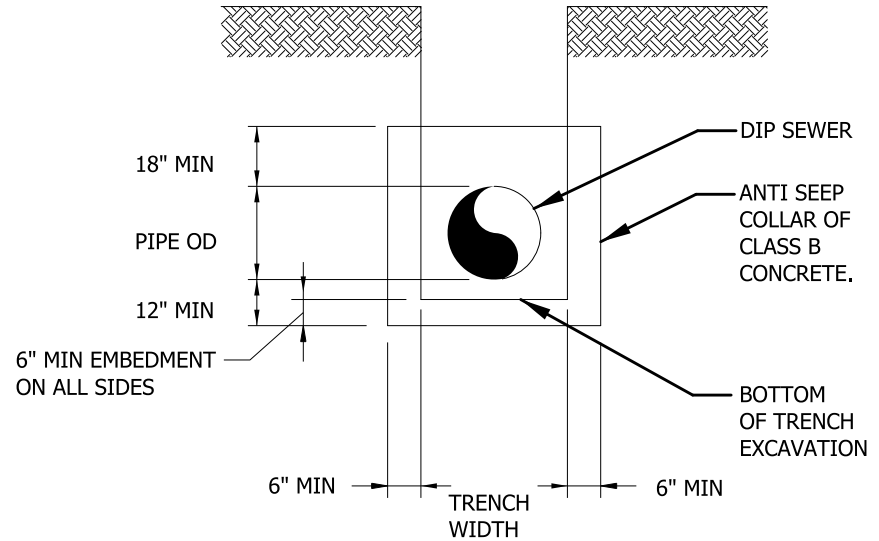

SECTION

CONCRETE ANTI-SEEP COLLAR



DATE:	REVISIONS

STANDARD DETAIL

DATE: 02/17/20
 SHEET 1 OF 1
 STD. No. S-1.13

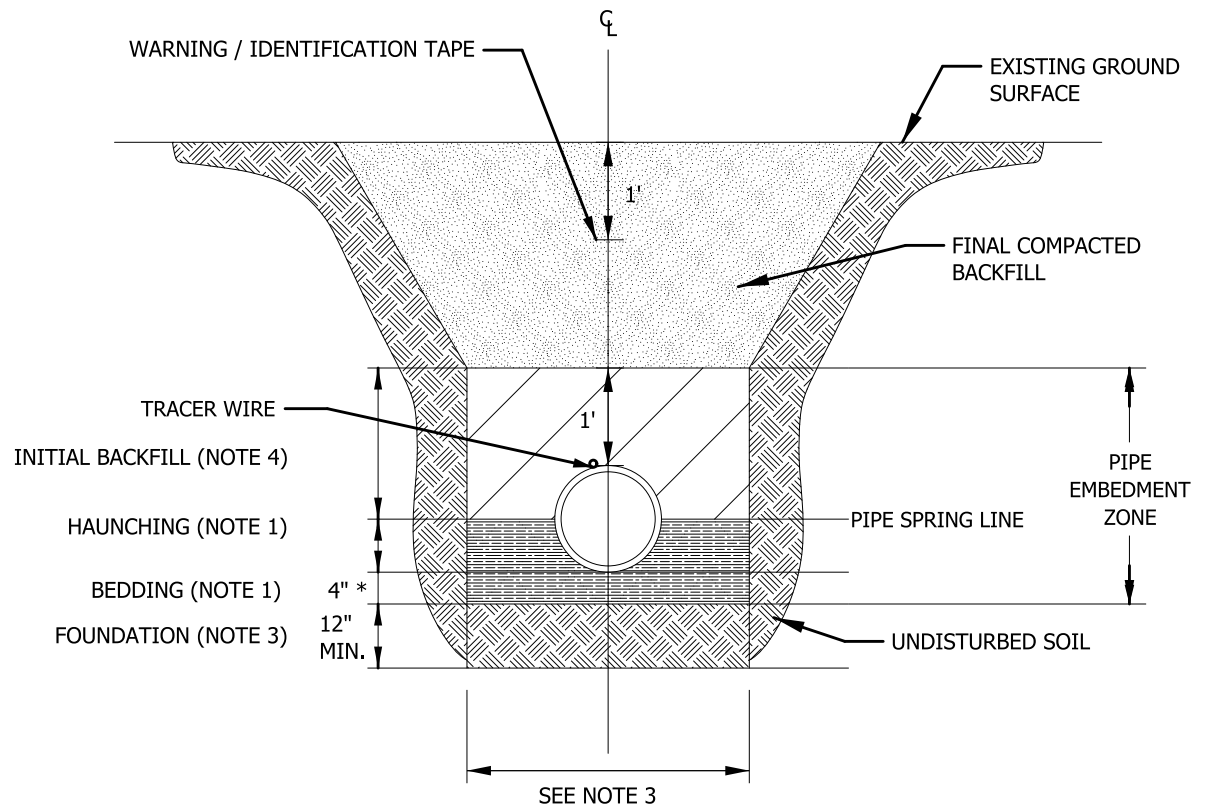

* 6" REQUIRED FOR PIPES GREATER THAN 30" IN DIAMETER

NOTES:

- 1) A MINIMUM OF 4" OF CLASS I STONE BEDDING IS REQUIRED UNDER ALL PIPE MATERIALS. PROVIDE STONE BEDDING IN UNSTABLE CLASS IV OR CLASS V SOILS, RUNNING WATER OR OTHER UNSTABLE SOIL CONDITIONS IN BEDDING AND HAUNCH ZONE. BACKFILL WITH CLASS I, II, OR III MATERIAL IN INITIAL BACKFILL.
- 2) FOR DEPTHS UP TO 14 FEET PROVIDE CLASS I STONE BEDDING AND CLASS I MATERIAL FOR HAUNCHING. BACKFILL WITH CLASS I, II, OR III MATERIAL IN INITIAL BACKFILL. FOR DEPTHS GREATER THAN 14 FEET, PROVIDE CLASS I STONE FOR BEDDING HAUNCHING AND INITIAL BACKFILL.
- 3) CLASS I FOUNDATION STONE SHALL BE REQUIRED WHEN SOIL CONDITIONS ARE UNSTABLE. UNDERCUT A MIN. OF 12" OR AS DIRECTED BY TOWN.
- 4) TRENCH WIDTH IS MINIMUM OF THE PIPE O.D. PLUS 18" AND MAXIMUM OF PIPE O.D. PLUS 24".
- 5) INITIAL BACKFILL SHALL BE PLACED AND COMPACTED IN 6" LIFTS. INITIAL BACKFILL SHALL CONTAIN NO MATERIAL OVER 1" IN DIAMETER, FROZEN LUMPS, OR DEBRIS.
- 6) BACKFILL SHALL BE COMPACTED IN ACCORDANCE WITH TOWN SPECIFICATIONS.

DUCTILE IRON (RIGID) PIPE GRAVITY SEWER BACKFILLING



DATE:	REVISIONS

STANDARD DETAIL

DATE: 02/17/20
SHEET 1 OF 1
STD. No. S-1.14

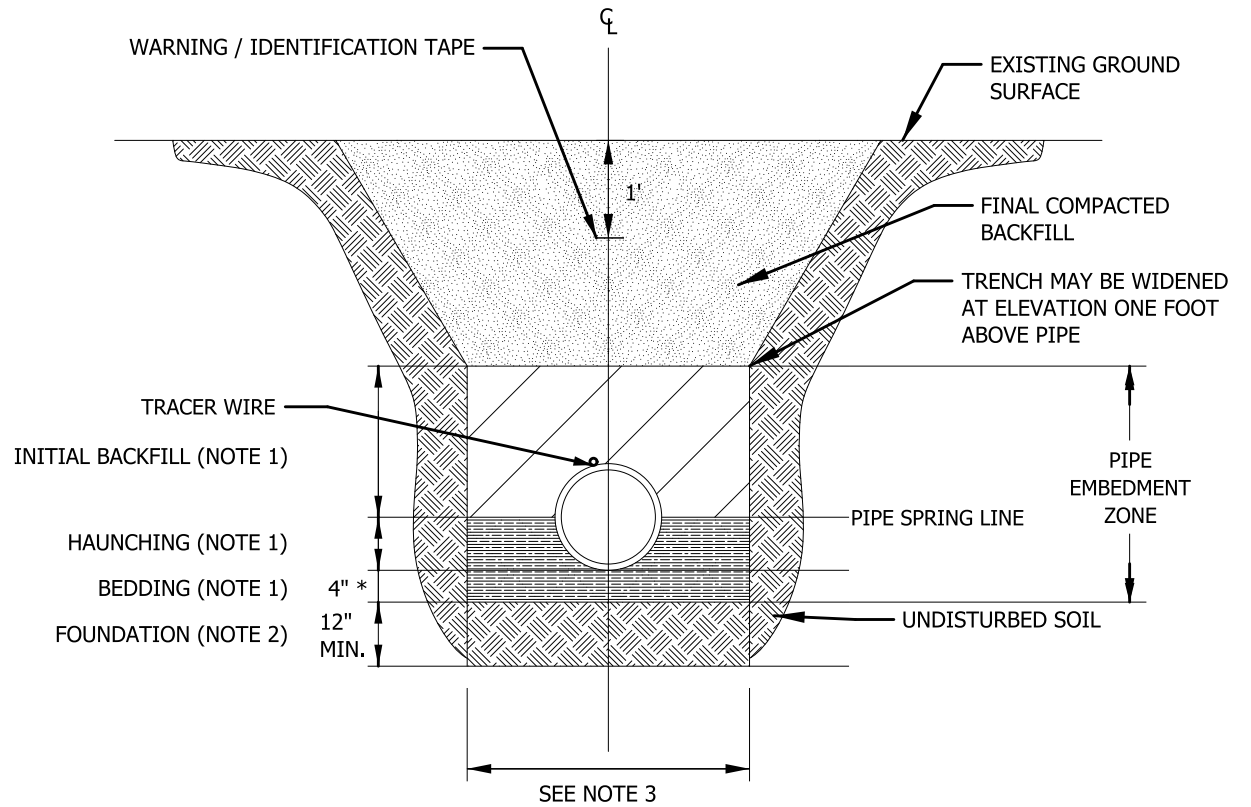

* 6" REQUIRED FOR PIPES GREATER THAN 30" IN DIAMETER

NOTES:

- 1) FOR DEPTHS UP TO 14 FEET PROVIDE A MINIMUM OF 4" CLASS I STONE FOR BEDDING AND HAUNCHING. BACKFILL WITH CLASS I, II, OR III MATERIAL IN INITIAL BACKFILL. FOR DEPTHS GREATER THAN 14 FEET, PROVIDE CLASS I STONE FOR BEDDING HAUNCHING AND INITIAL BACKFILL.
- 2) CLASS I FOUNDATION STONE SHALL BE REQUIRED WHEN SOIL CONDITIONS ARE UNSTABLE. UNDERCUT A MIN. OF 12" OR AS DIRECTED BY TOWN.
- 3) TRENCH WIDTH IS MINIMUM OF THE PIPE O.D. PLUS 18" AND MAXIMUM OF PIPE O.D. PLUS 24".
- 4) INITIAL BACKFILL SHALL BE PLACED AND COMPACTED IN 6" LIFTS. INITIAL BACKFILL SHALL CONTAIN NO MATERIAL OVER 1" IN DIAMETER, FROZEN LUMPS, OR DEBRIS.
- 5) BACKFILL SHALL BE COMPACTED IN ACCORDANCE WITH TOWN SPECIFICATIONS.

PVC (FLEXIBLE) PIPE GRAVITY SEWER BACKFILLING



DATE:	REVISIONS

STANDARD DETAIL

DATE: 02/17/20
SHEET 1 OF 1
STD. No. S-1.15

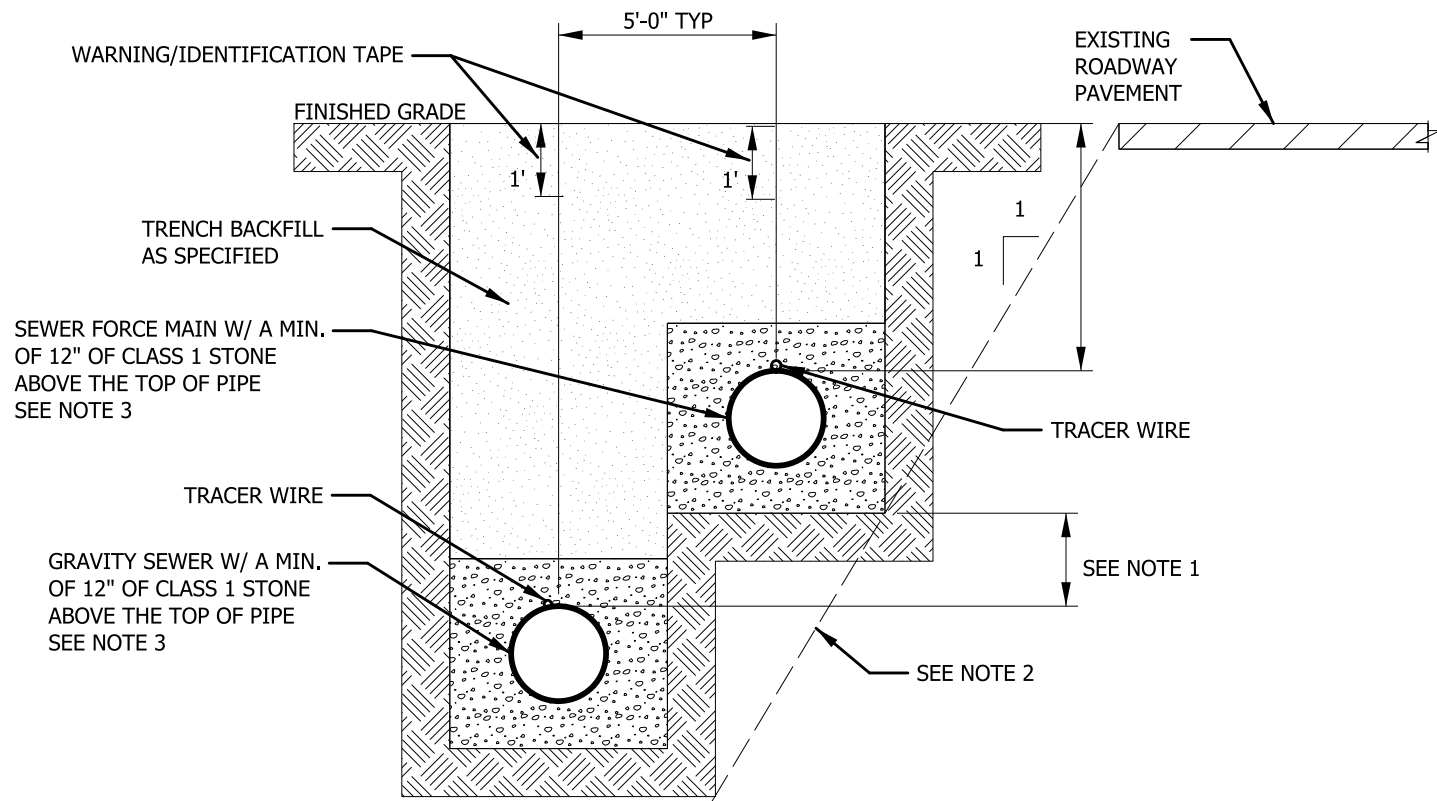

NOTES:

- 1) PROVIDE SUFFICIENT VERTICAL CLEARANCE BETWEEN GRAVITY SEWER AND FORCE MAIN SO AS TO ALLOW FUTURE MAIN AND SERVICE CONNECTIONS TO GRAVITY SEWER.
- 2) ALL TRENCHING ADJACENT TO ROADWAY SHALL BE OUTSIDE THE THEORETICAL 1:1 SLOPE FROM THE EXISTING EDGE OF PAVEMENT.
- 3) ALL OTHER BEDDING/BACKFILLING SHALL MEET THE REQUIREMENTS OF DETAILS S-1.15 AND S-1.16 AS APPLICABLE, AND THE STANDARD SPECIFICATIONS.

STANDARD TRENCH FOR PARALLEL GRAVITY SEWER AND FM



DATE:	REVISIONS

STANDARD DETAIL

DATE: 02/17/20
SHEET 1 OF 1
STD. No. S-1.16

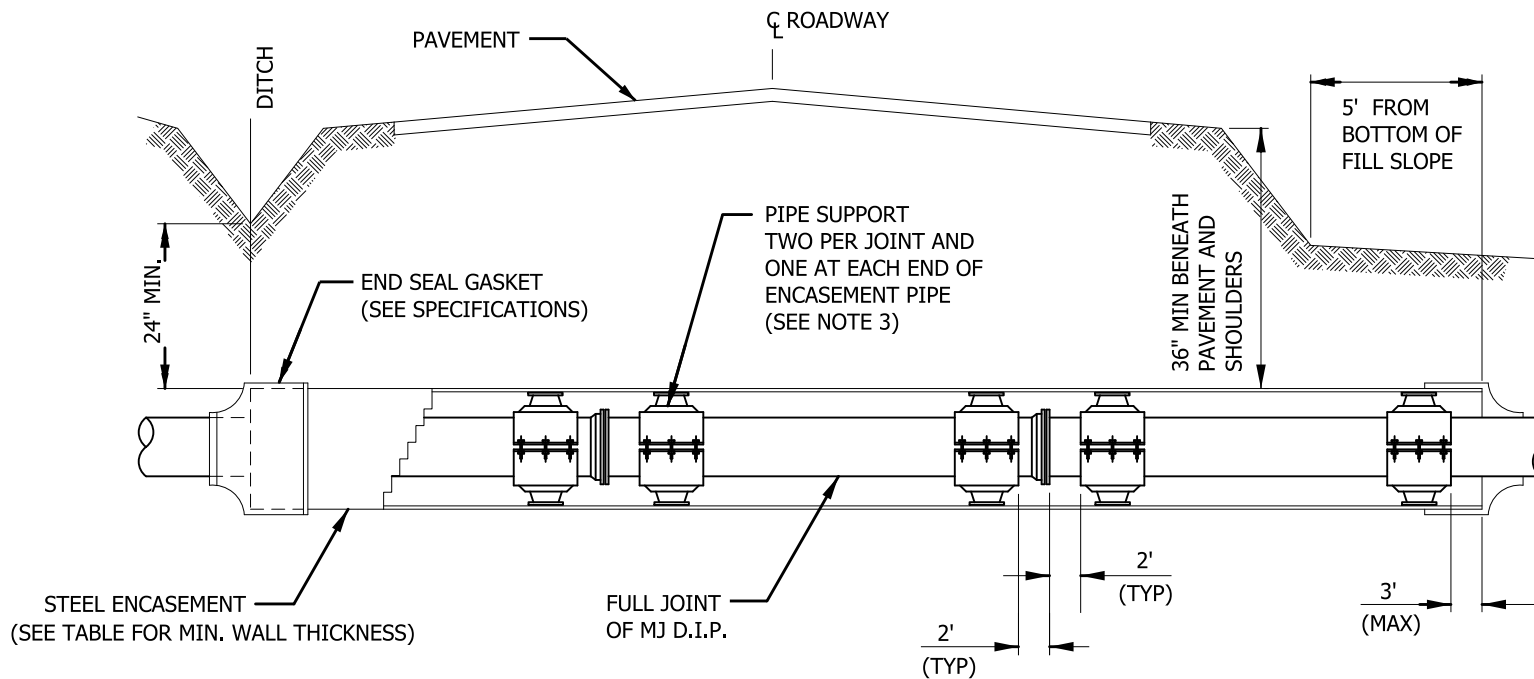

NOTES:

- 1) ENCASEMENT TO EXTEND A MINIMUM OF 5' BEHIND CURB SECTIONS.
- 2) ENCASEMENT TO EXTEND FROM DITCH LINE TO DITCH LINE IN CUT SECTIONS.
- 3) SEE PIPE SUPPORTS IN SPECIFICATIONS.

ENCASEMENT PIPE WALL THICKNESS			
ROADWAY		RAILROAD	
PIPE SIZE (O.D. INCHES)	WALL THICKNESS	PIPE SIZE (O.D. INCHES)	WALL THICKNESS
4 - 12 3/4	0.188	12 3/4 & UNDER	0.188
16 - 24	0.250	16	0.281
30	0.312	24	0.375
36	0.375	30	0.469
42	0.500	36	0.531
48	0.500	42	0.625
		48	0.688

PIPE INSTALLATION IN STEEL ENCASEMENT

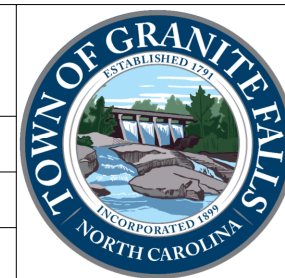

DATE:	REVISIONS

STANDARD DETAIL

DATE: 02/17/20
 SHEET 1 OF 1
 STD. No. S-1.17

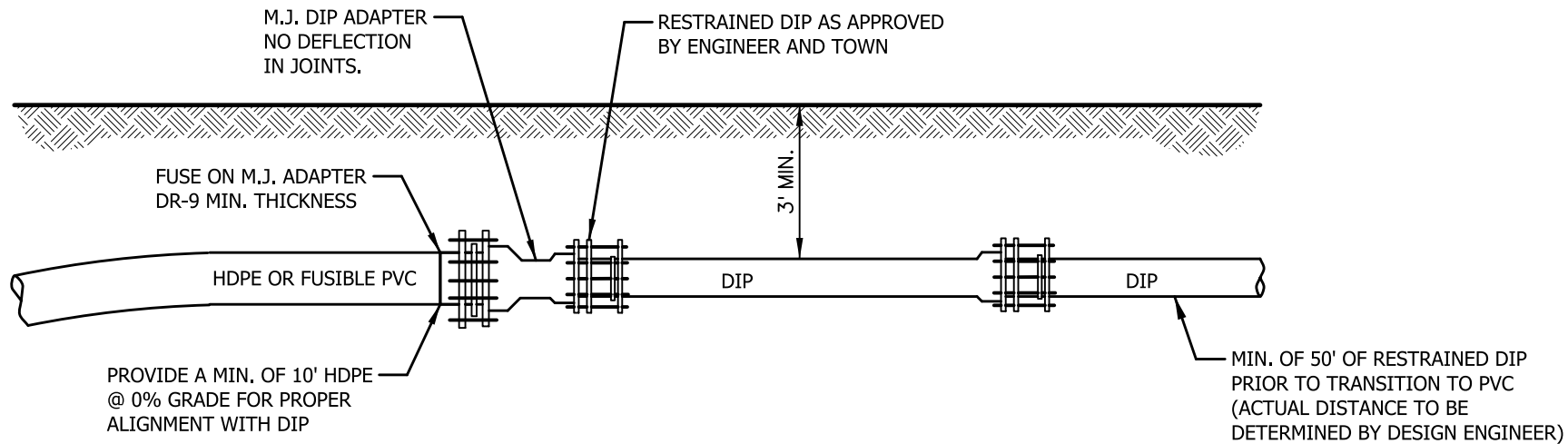

HDPE/FUSIBLE PVC TRANSITION



DATE:	REVISIONS

STANDARD DETAIL

DATE: 02/17/20
SHEET 1 OF 1
STD. No. S-1.18

1 PIPE DIAMETER (INCH)	2 MINIMUM TIME (MIN:SEC)	3 LENGTH FOR MINIMUM TIME (FEET)	4 TIME FOR LONGER LENGTH (SEC)	5 SPECIFICATION TIME FOR LENGTH (L) SHOWN (MIN:SEC)								
				100FT	150FT	200FT	250FT	300FT	350FT	400FT	450FT	
4	3:46	597	.380 L	3:46	3:46	3:46	3:46	3:46	3:46	3:46	3:46	3:46
6	5:40	398	.854 L	5:40	5:40	5:40	5:40	5:40	5:40	5:40	5:42	6:24
8	7:34	298	1.520 L	7:34	7:34	7:34	7:36	7:36	8:52	10:08	11:24	
10	9:26	239	2.374 L	9:26	9:26	9:26	9:53	11:52	13:51	15:49	17:48	
12	11:20	199	3.418 L	11:20	11:20	11:24	14:15	17:05	19:56	22:47	25:38	
15	14:10	159	5.324 L	14:10	14:10	17:48	22:15	26:42	31:09	31:36	40:04	
18	17:00	133	7.692 L	17:00	19:13	25:38	32:03	38:27	44:52	51:16	57:41	
21	19:50	114	10.470 L	19:50	26:10	34:54	43:37	52:21	61:00	69:48	78:31	
24	22:40	99	13.674 L	22:47	34:11	45:34	56:58	68:22	79:46	91:10	102:33	
27	25:30	88	17.306 L	28:51	43:16	57:41	72:07	86:32	100:57	115:22	129:48	
30	28:20	80	21.366 L	35:37	53:25	71:13	89:02	106:50	124:38	142:26	160:15	
33	31:10	72	25.852 L	43:05	64:38	86:10	107:43	129:16	150:43	172:21	193:53	
36	34:00	66	30.768 L	51:17	76:55	102:34	128:12	153:50	179:29	205:07	230:46	

LOW PRESSURE AIR TESTING FOR GRAVITY SEWER MAINS



DATE:	REVISIONS

STANDARD DETAIL

DATE: 02/17/20
SHEET 1 OF 1
STD. No. S-1.19

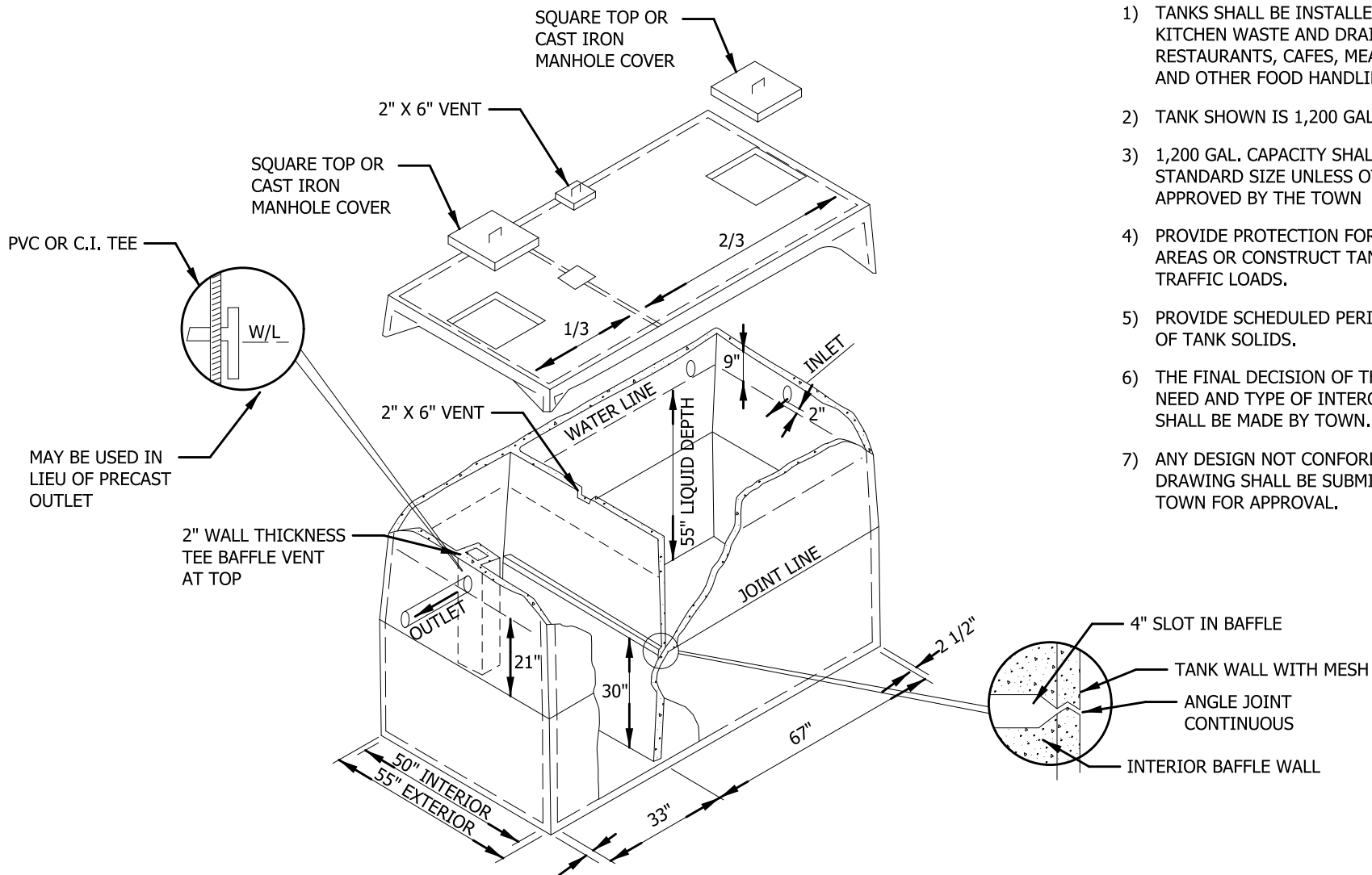

- NOTES:
- 1) TANKS SHALL BE INSTALLED ON ALL KITCHEN WASTE AND DRAIN LINES FROM RESTAURANTS, CAFES, MEAT MARKETS, AND OTHER FOOD HANDLING ESTABLISHMENTS.
 - 2) TANK SHOWN IS 1,200 GAL. CAPACITY.
 - 3) 1,200 GAL. CAPACITY SHALL BE THE STANDARD SIZE UNLESS OTHERWISE APPROVED BY THE TOWN
 - 4) PROVIDE PROTECTION FOR TANK IN TRAFFIC AREAS OR CONSTRUCT TANK TO WITHSTAND TRAFFIC LOADS.
 - 5) PROVIDE SCHEDULED PERIODIC CLEANING OF TANK SOLIDS.
 - 6) THE FINAL DECISION OF THE NEED AND TYPE OF INTERCEPTOR SHALL BE MADE BY TOWN.
 - 7) ANY DESIGN NOT CONFORMING TO THIS DRAWING SHALL BE SUBMITTED TO TOWN FOR APPROVAL.

STANDARD TWO COMPARTMENT GREASE INTERCEPTOR TANK

STANDARD DETAIL

DATE:	REVISIONS

DATE: 02/17/20
SHEET 1 OF 1
STD. No. S-1.20



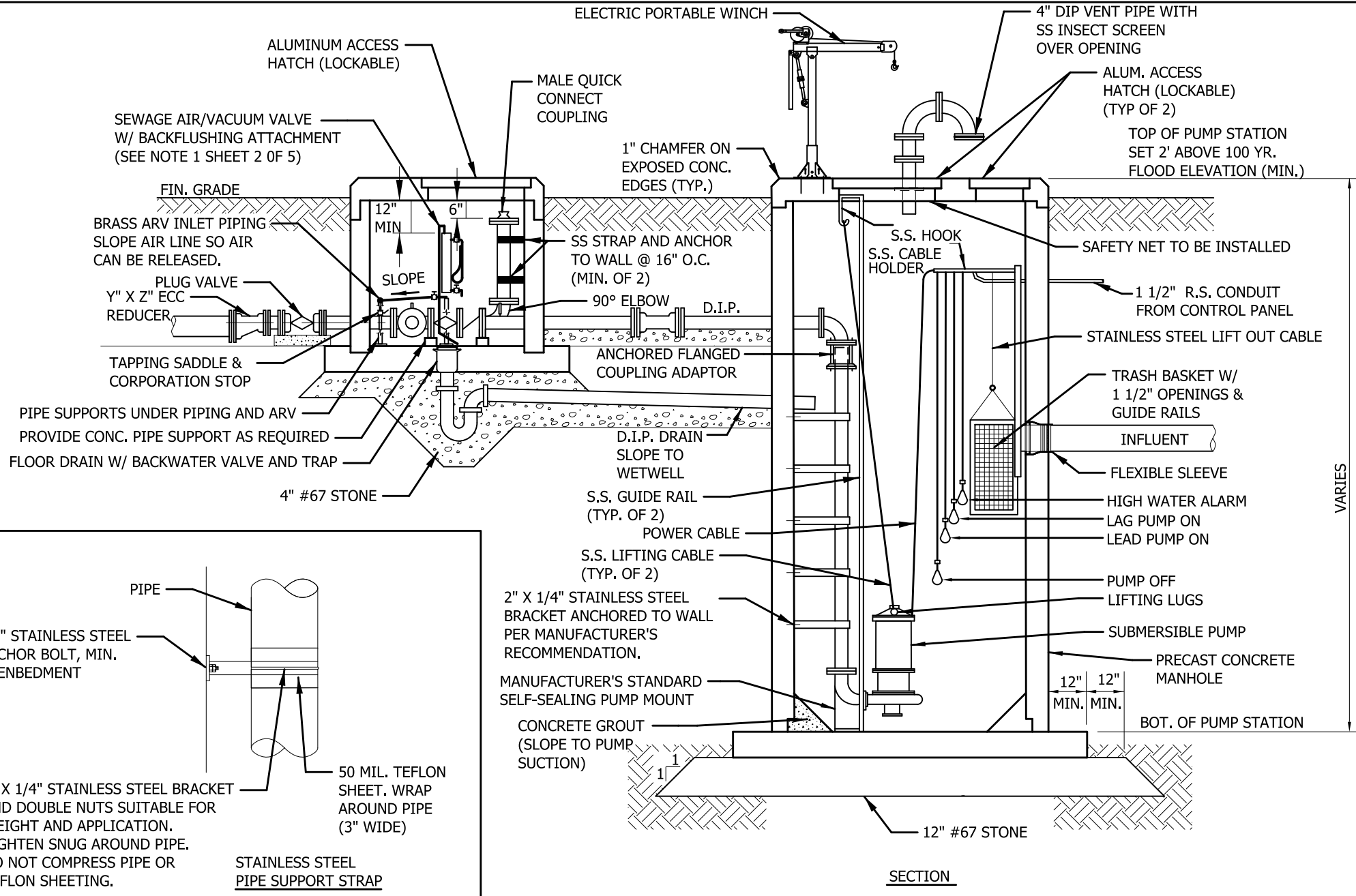

STANDARD PUMP STATION LAYOUT

DATE:	REVISIONS

STANDARD DETAIL

DATE: 02/17/20
SHEET 1 OF 5
STD. No. S-1.21



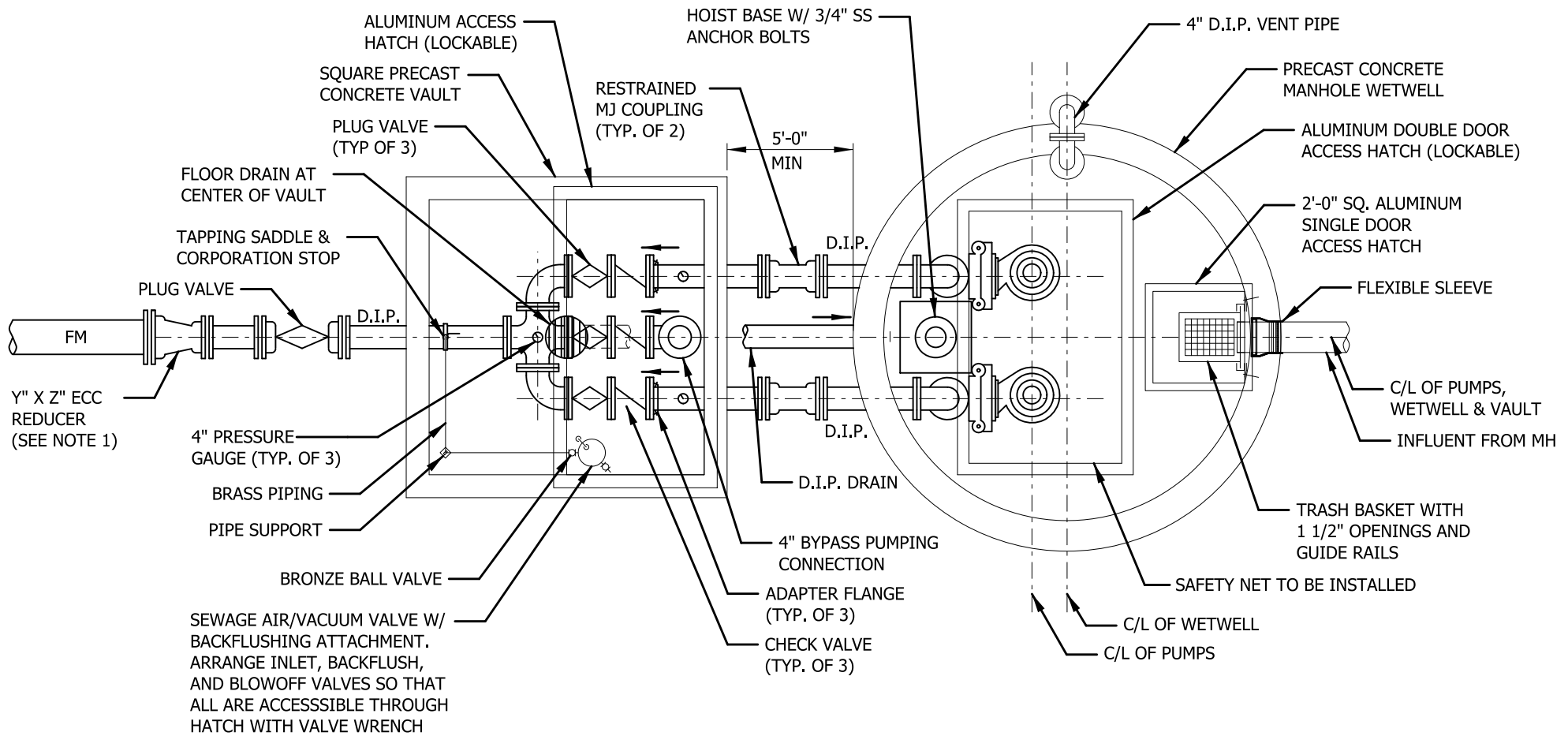

PLAN

NOTES:

- 1) VALVE VAULT EFFLUENT PIPING IS SHOWN FOR A FORCE MAIN ON A DOWNWARD SLOPE AWAY FROM PUMP STATION. FOR A FORCE MAIN ON AN UPWARD SLOPE AWAY FROM PUMP STATION, THE DESIGNER MAY CONSIDER ROTATING THE ECCENTRIC REDUCER (IF USED) AND DELETING THE ARV.
- 2) USE D.I.P. THROUGHOUT THE PUMP STATION.
- 3) ACCESS HATCHES TO BE SIZED TO FACILITATE THE EASY REMOVAL OF PUMPS, VALVES, ETC.
- 4) LAYOUT SHOWN IS TYPICAL FOR THE TOWN OF GRANITE FALLS. FINAL DESIGN AND LAYOUT OF ALL PUMP STATIONS MUST BE APPROVED BY THE TOWN.

STANDARD PUMP STATION



DATE:	REVISIONS

STANDARD DETAIL

DATE: 02/17/20
SHEET 2 OF 5
STD. No. S-1.21

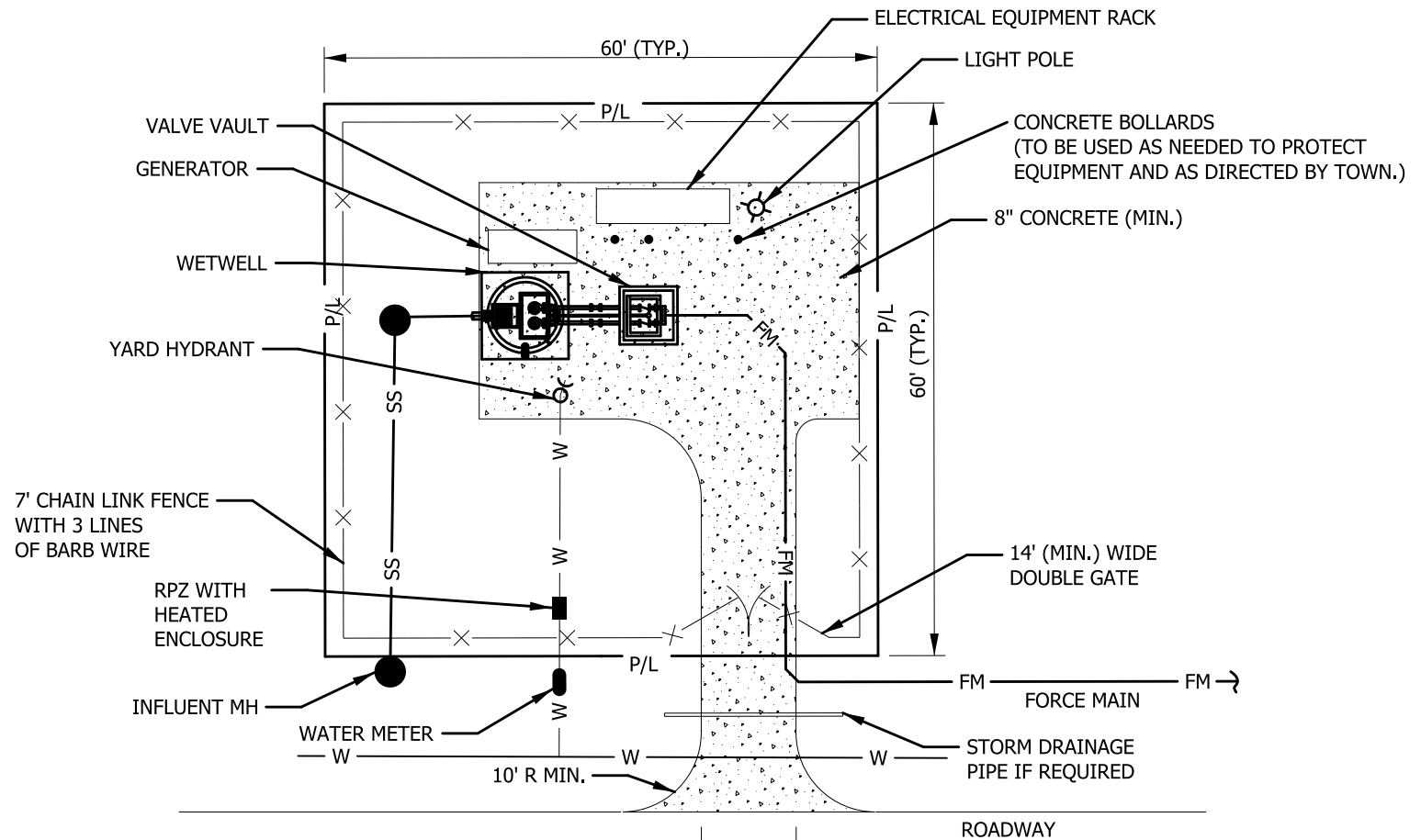

NOTES:

- 1) ORIENTATION OF COMPONENTS MAY BE ADJUSTED TO SUIT SITE CONDITIONS.
- 2) MAINTAIN REQUIRED SEPARATION BETWEEN SEWER AND WATER LINES.
- 3) FOR SITES WHERE TYPICAL DIMENSIONS CANNOT BE ATTAINED, PROPOSED LAYOUT MUST RECEIVE PRIOR WRITTEN APPROVAL BY THE TOWN.

STANDARD PUMP STATION LAYOUT



DATE:	REVISIONS

STANDARD DETAIL

DATE: 02/17/20
SHEET 3 OF 5
STD. No. S-1.21

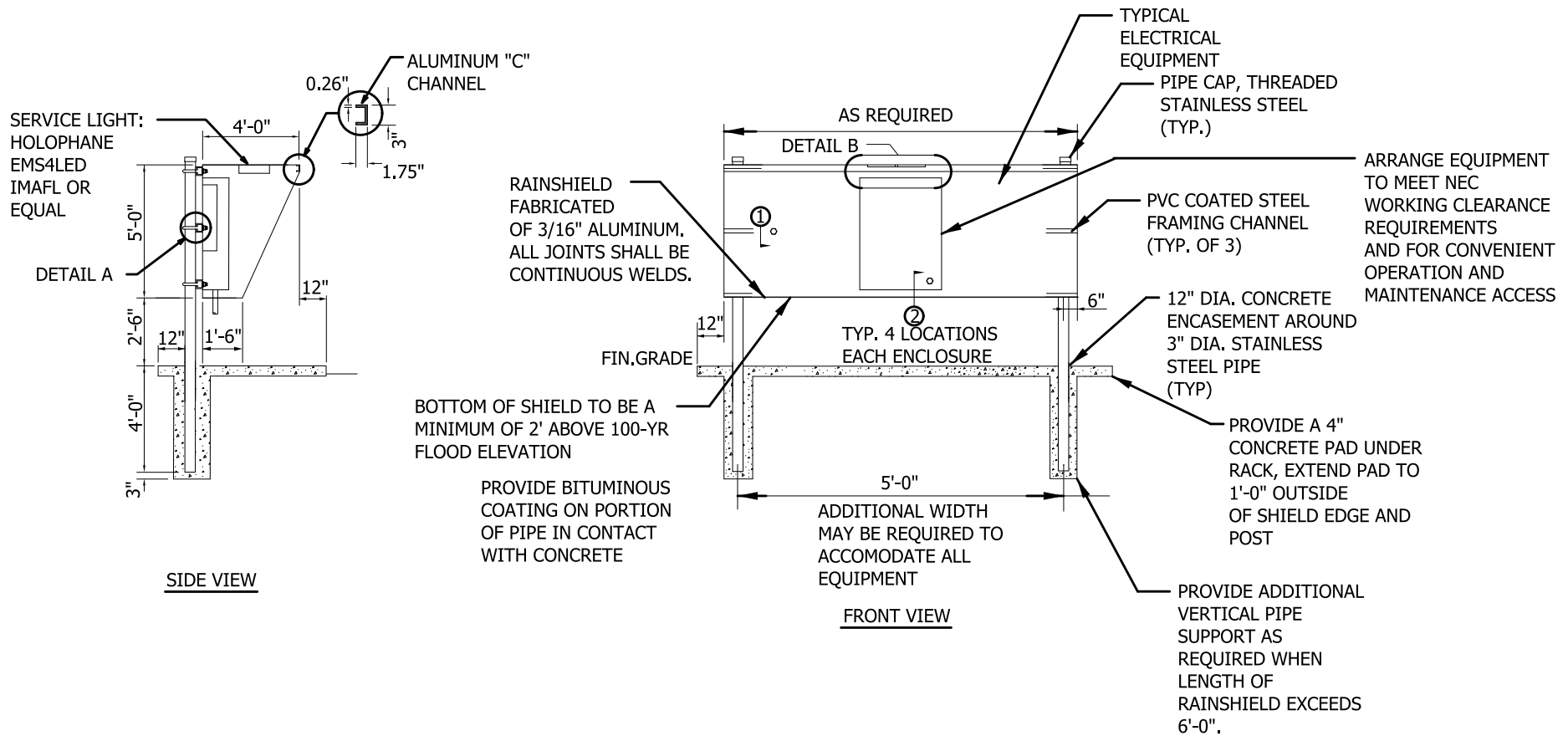

STANDARD PUMP STATION EQUIPMENT MOUNTING RACK



DATE:	REVISIONS

STANDARD DETAIL

DATE: 02/17/20
SHEET 4 OF 5
STD. No. S-1.21

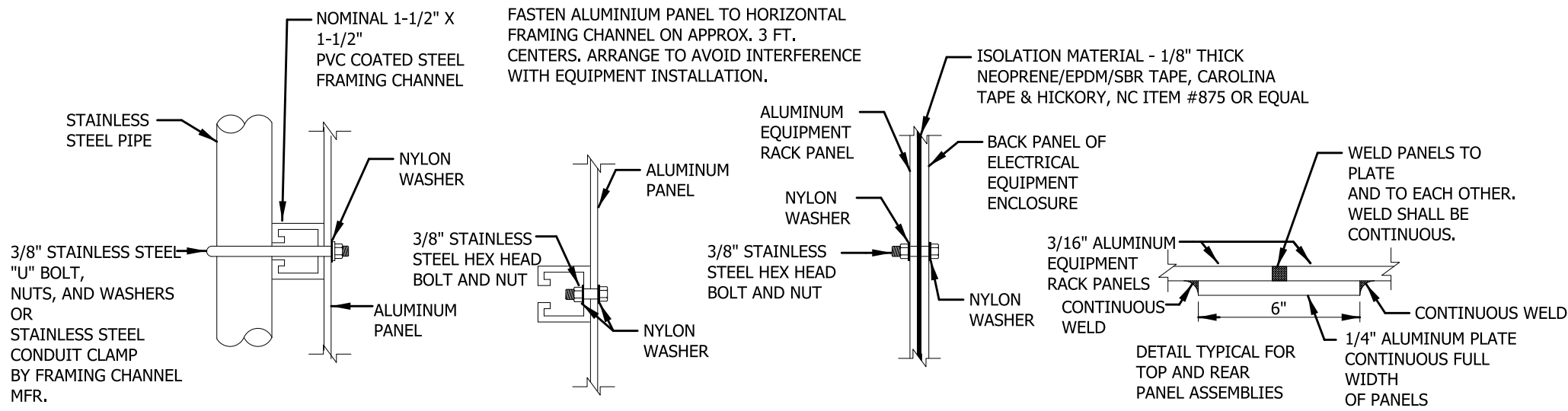

PROVIDE SPLICE IF LENGTH OF EQUIPMENT RACK EXCEEDS STANDARD PANEL LENGTH.

STANDARD PUMP STATION EQUIPMENT MOUNTING RACK

DATE:	REVISIONS

STANDARD DETAIL

DATE: 02/17/20
SHEET 5 OF 5
STD. No. S-1.21

